

ECE DEPARTMENT

5<sup>TH</sup> SEM

OPTICAL FIBER

COMMUNICATION

# UNIT 1

## BASIC OF COMMUNICATION SYSTEM.

A basic communication system consists of certain units called constituents or states.

# BLOCK DIAGRAM OF COMMUNICATION SYSTEM

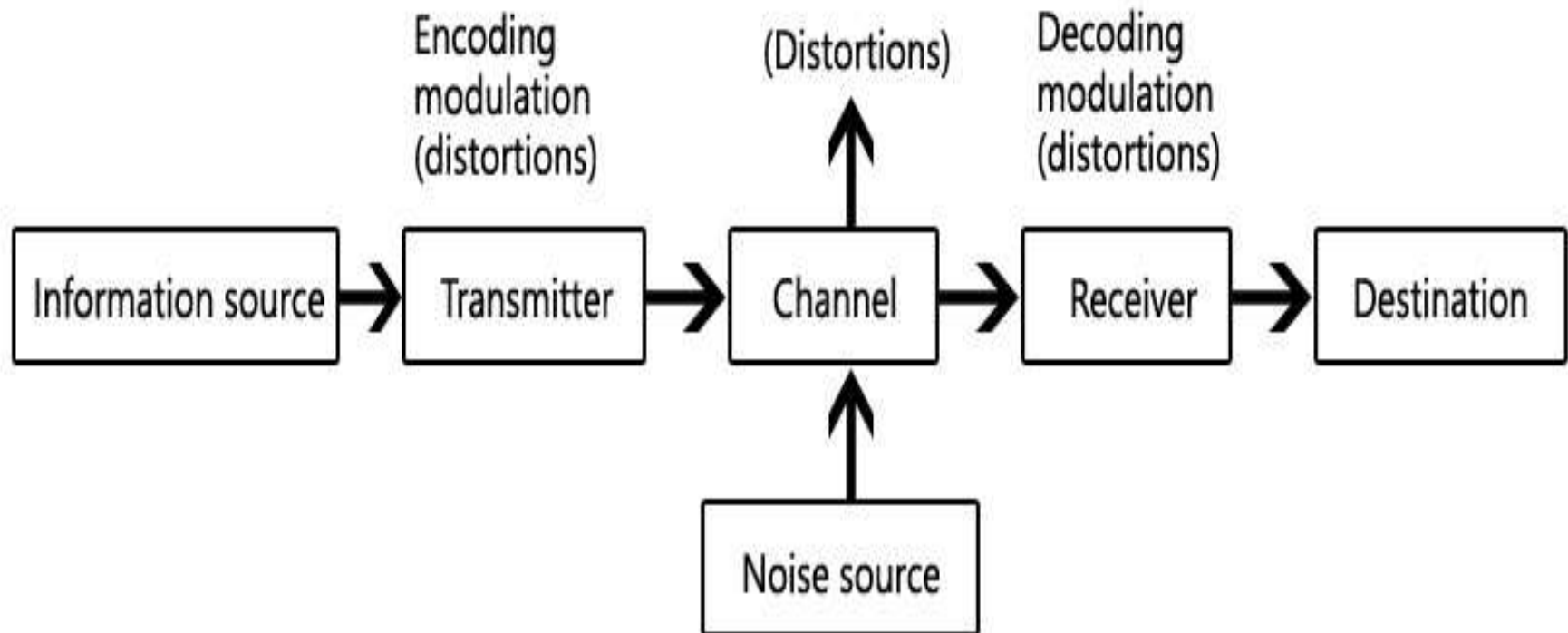

# The basic states of basic communication system are :

- ❖ **INFORMATION SOURCE** – The basic purpose of a information is to generate the message or information which is to be transmitted.
- ❖ **TRANSMITTER** –The information generated by the source is forwarded to the transmitter .The transmitter processes the and amplifies the message by using small signal into large signals.

- ▶ THE CHANNEL–Transmitter of message from transmitter to receiver needs a medium through which the message can travel effectively .This medium is known as channel .
- ▶ NOISE–Noise is defined as the unwanted form of energy which tends to interfere with the proper reception and reproduction of the transmitted signals.

## ▶ RECEIVER-

Receiver is an electronic device that receives the message signal and converts the information by it into usable form.

# OPTICAL FIBER COMMUNICATION SYSTEM

- ▶ The output of a information source which is an electrical signal ,which fed to an electrical drive circuit which drives an optical source to modulate the light wave carrier .The optical source converts the electrical signal into optical signal by using a semiconductor laser or light emitting diode and medium consists of an optical fiber cable.

## Block Diagram of Optical Fiber Communication System

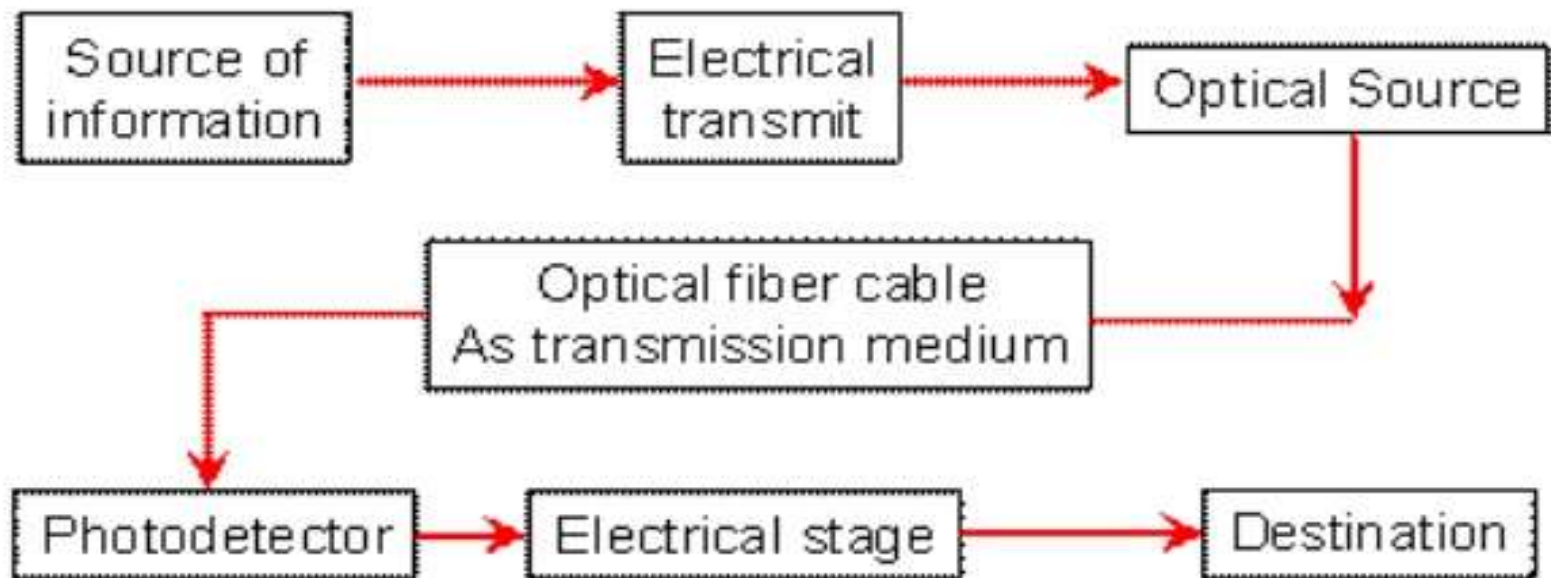

**Figure: Basic Block Diagram of Optical Communication System**

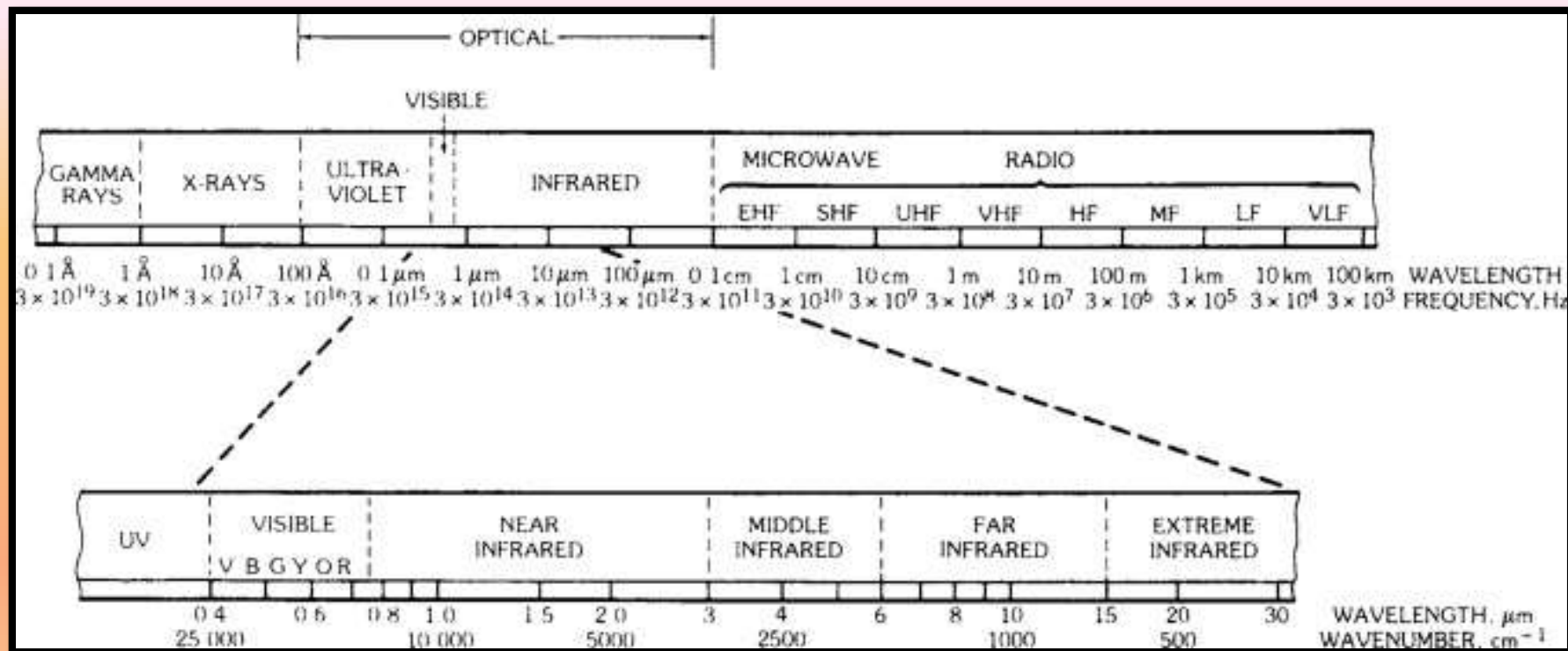

# Structure of optical fiber

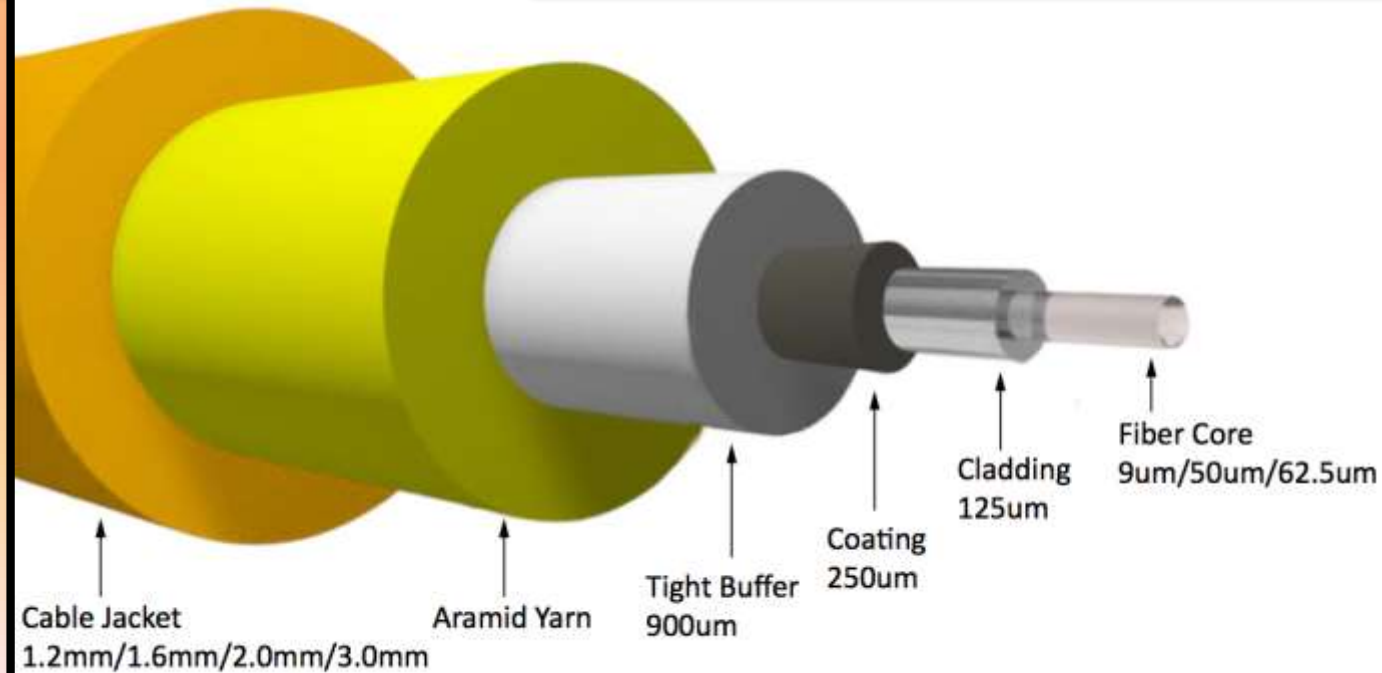
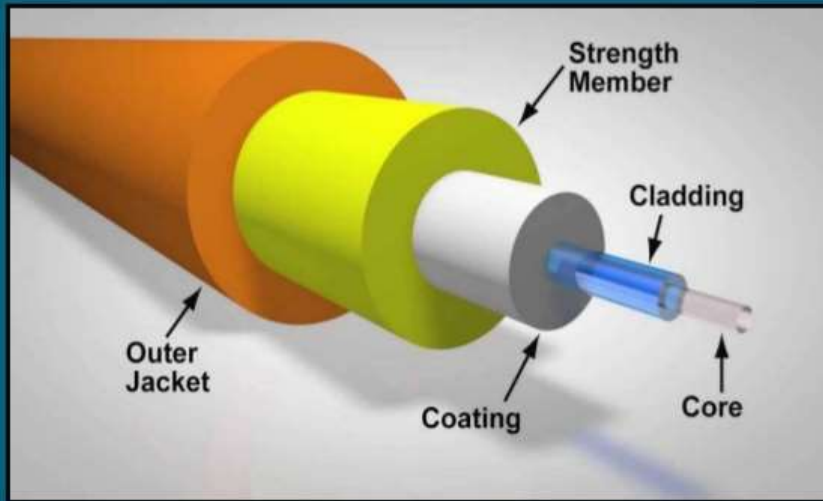

# ADVANTAGES

- ▶ Very high bandwidth.
- ▶ Very small size& weight
- ▶ Immunity to interference
- ▶ Electrical isolation
- ▶ Low transmission loss
- ▶ Signal security
- ▶ High reliability
- ▶ Ruggedness
- ▶ Low cost
- ▶ Immunity to moisture

# Disadvantages

- ▶ The optical fiber communication is less suited for broadcasting purposes because of the narrow beam of light produced in optical fiber cable.
- ▶ Optical fiber cables are not directly suited for multi-access use.
- ▶ The noise level in optical receiver is very high because of the quantum limited nature of optical detector.
- ▶ The optical beam generation efficiency of optical carrier is very low.

# APPLICATIONS

- ▶ Long distance telecommunication
- ▶ Inter -exchange junction
- ▶ Video transmission
- ▶ Broadband services
- ▶ Computer data communication
- ▶ Military application
- ▶ High electromagnetic interference areas
- ▶ Non communication application
- ▶ Fiber in subscriber loop

# CRITICAL ANGLE

- ▶ The angle of incidence beyond which rays of light passing through a denser medium to the surface of a less dense medium are no longer refracted but totally reflected .

# Critical Angle

$n_1$  = refractive index of the denser medium

$n_2$  = refractive index of the rarer medium

$\theta_1$  = angle of incidence

$\theta_2$  = angle of refraction

$\theta_c$  = critical angle

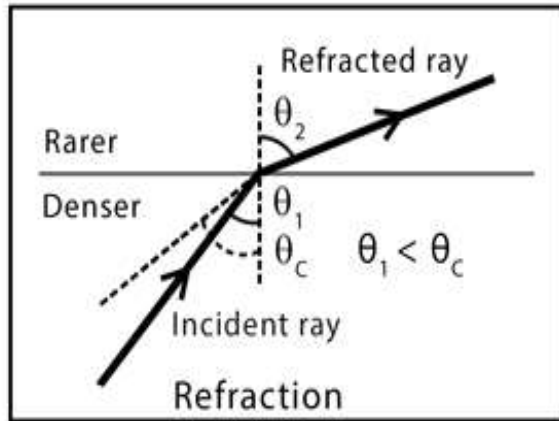

Snell's law of refraction

$$n_1 \sin \theta_1 = n_2 \sin \theta_2$$

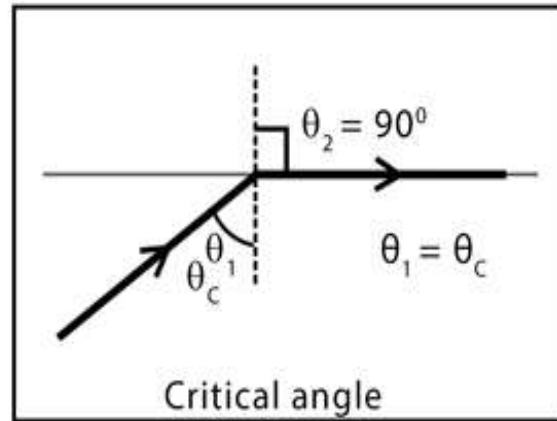

For critical angle,  $\theta_2 = 90^\circ$   
Therefore,  $n_1 \sin \theta_1 = n_2 \sin 90^\circ = n_2$   
 $\Rightarrow \theta_1 = \theta_c = \arcsin(n_2/n_1)$

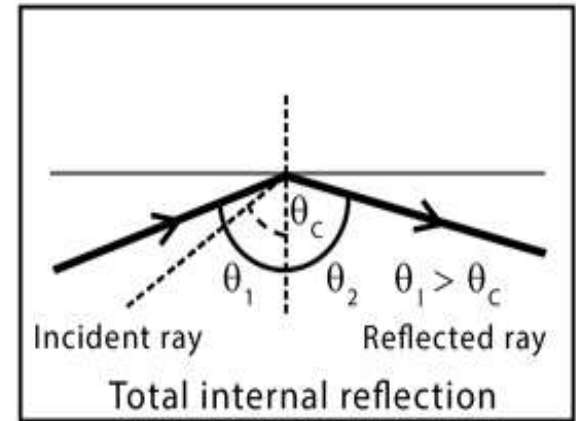

For total internal reflection  
to occur,  $\theta_1 > \theta_c$

# TOTAL INTERNAL REFLECTION

- ▶ The complete reflection of a light ray reaching an interface with a less dense medium when the angle of incidence exceeds the critical angle.

# Total Internal Reflection

- At the critical angle,  $\theta_c$ , the angle of refraction is  $90^\circ$
- The refracted ray points along the surface

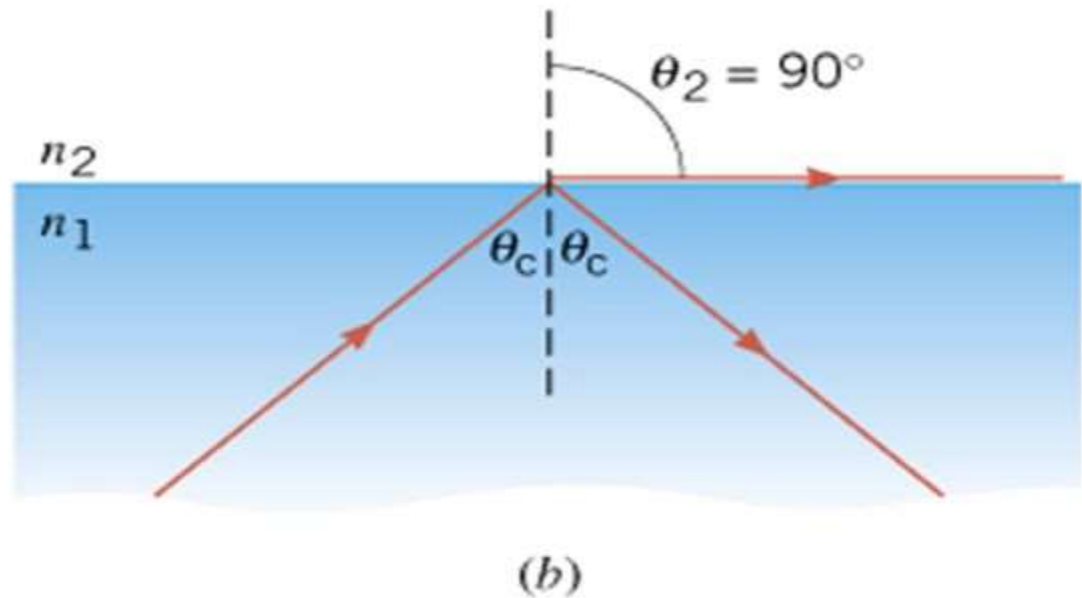

# ACCEPTANCE ANGLE

- **Acceptance angle** is maximum angle at which a light ray enters into core and propagate through it in zigzag path

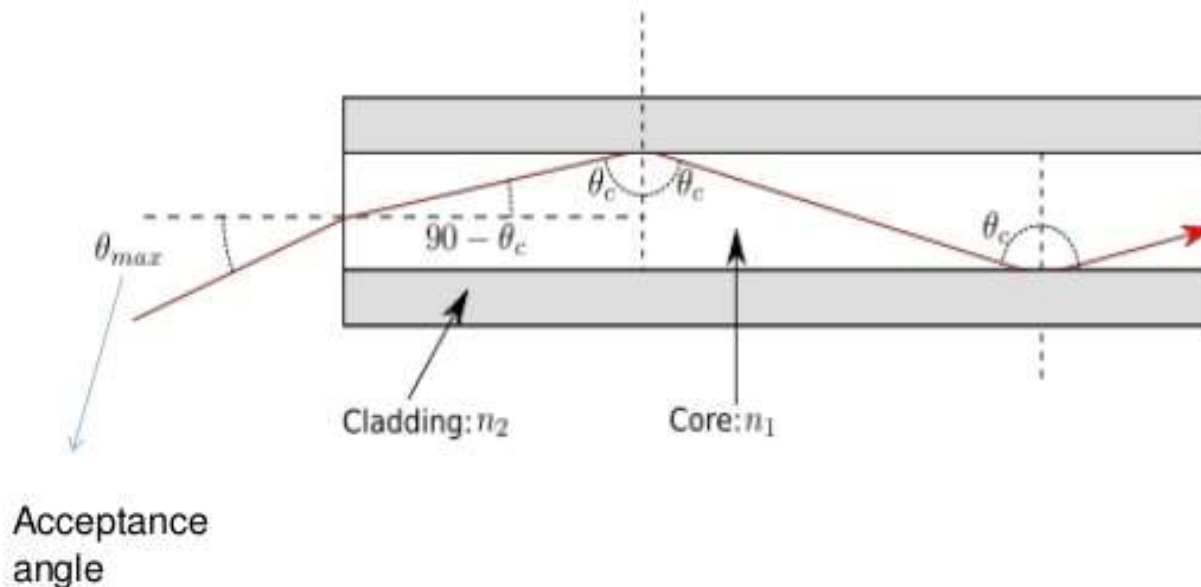

# Acceptance angle

- The maximum angle of incidence that a ray can make that will result in total internal reflection is called acceptance angle

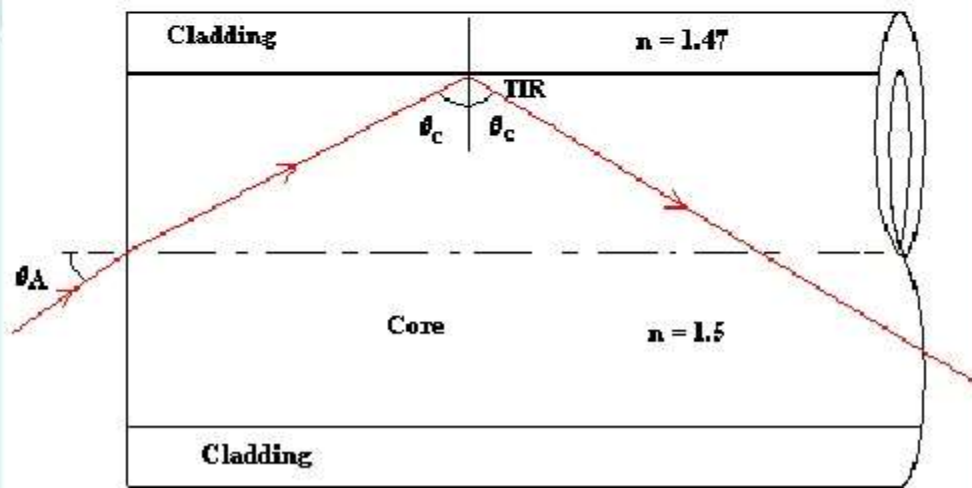

# Numerical aperture (NA)

The NA defines a **cone of acceptance** for light that will be guided by the fiber

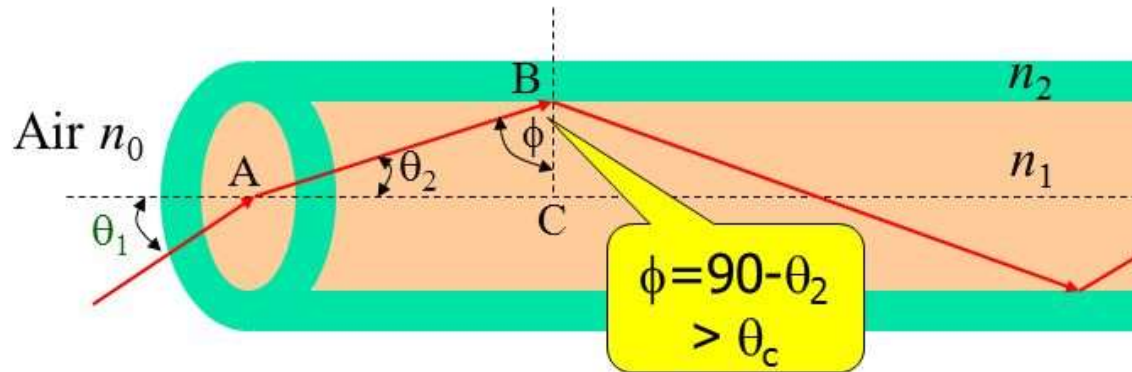

At the air core interface  $n_0 \sin \theta_1 = n_1 \sin \theta_2$

From the triangle ABC  $\phi = \frac{\pi}{2} - \theta_2$

# Unit 2: INTRODUCTION

- 1.Types of optical fibers.
- 2.Mono (single) mode optical fiber.
- 3.Multimode optical fiber.
- 4.Step index fiber.
- 5.Graded index fiber.
- 6.Acceptance angle
- 7.Different types of optical fiber cables.

# TYPES OF OPTICAL FIBERS :

1. Mono Mode optical fiber
2. Multimode optical fiber

Also , the optical fiber are divided into two types according to the variation in the material composition of the core which is based on the refractive index of the core.

1. Step index fiber
2. Graded index fiber

## **MONO (SINGLE) MODE OPTICAL FIBER**

Single mode optical fiber is a type of fiber optical cable through which only one light signal can travel at a time thus attenuation is very less .

So , it can be in long distance cables . The core of a signal mode fiber is normally 9um wide . The capacity to transmit information by using single mode fiber is high because it can retain fidelity of each light pulse over long distance . Single mode fiber have evolved into more complex designs.

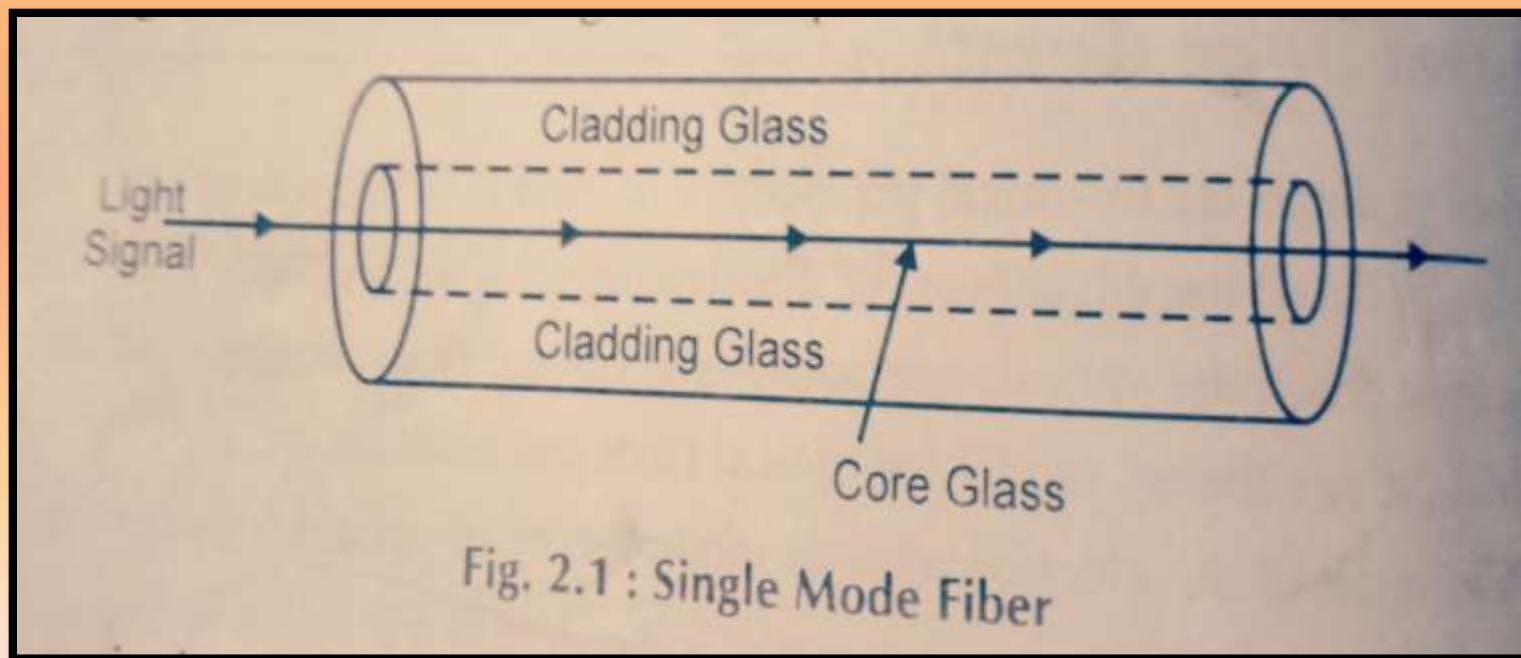

# MULTIMODE OPTICAL FIBER

Multimode optical fiber is a type of fiber optical cable through which several light signals can travel at a time. Multimode fiber comes in two standard widths, 62.5 micron and 50 micron. Multimode fiber is best suited for short distance transmission. The core diameter of multimode fiber is much larger than the single mode fiber due to which a large number of modes can exist. Multimode fiber can be categorized as step index or index fiber.

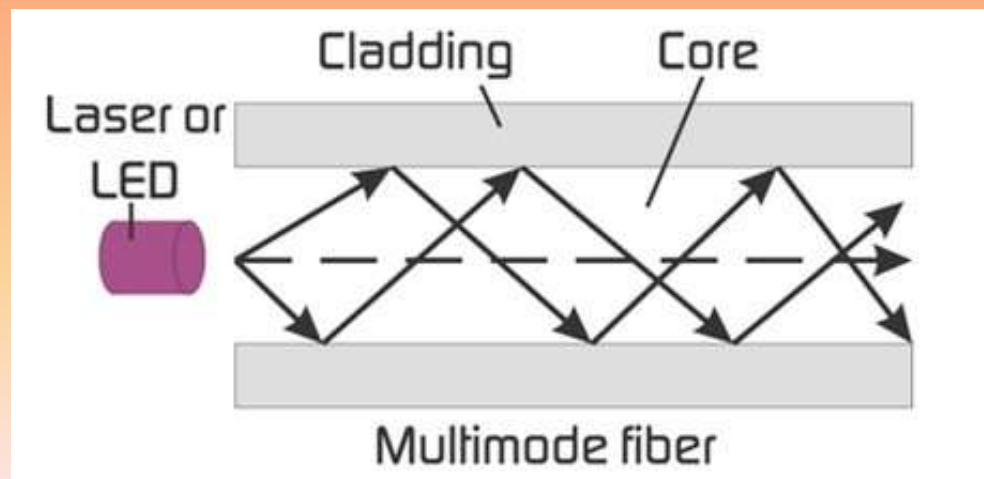

## Step index fiber

Step index fiber is the fiber in which the refractive index ( $n_1$ ) of the core is constant and the refractive index ( $n_2$ ) of the cladding is slightly

$$n(r) = \begin{cases} n_1 & r < a \text{ (core)} \\ n_2 & r > a \text{ (cladding)} \end{cases}$$

Step index fiber may be categorized as single mode step index fiber and multimode step index fiber .

**(a) Step index single mode fiber** = The single mode step index fiber allows the propagation of only one transverse electromagnetic mode . The core diameter of the single mode step index fiber must be of the order of 2 to 10  $\mu\text{m}$  . The single mode step index fiber has the distinct advantages of no inter modal dispersion because only one mode is transmitted at a time.

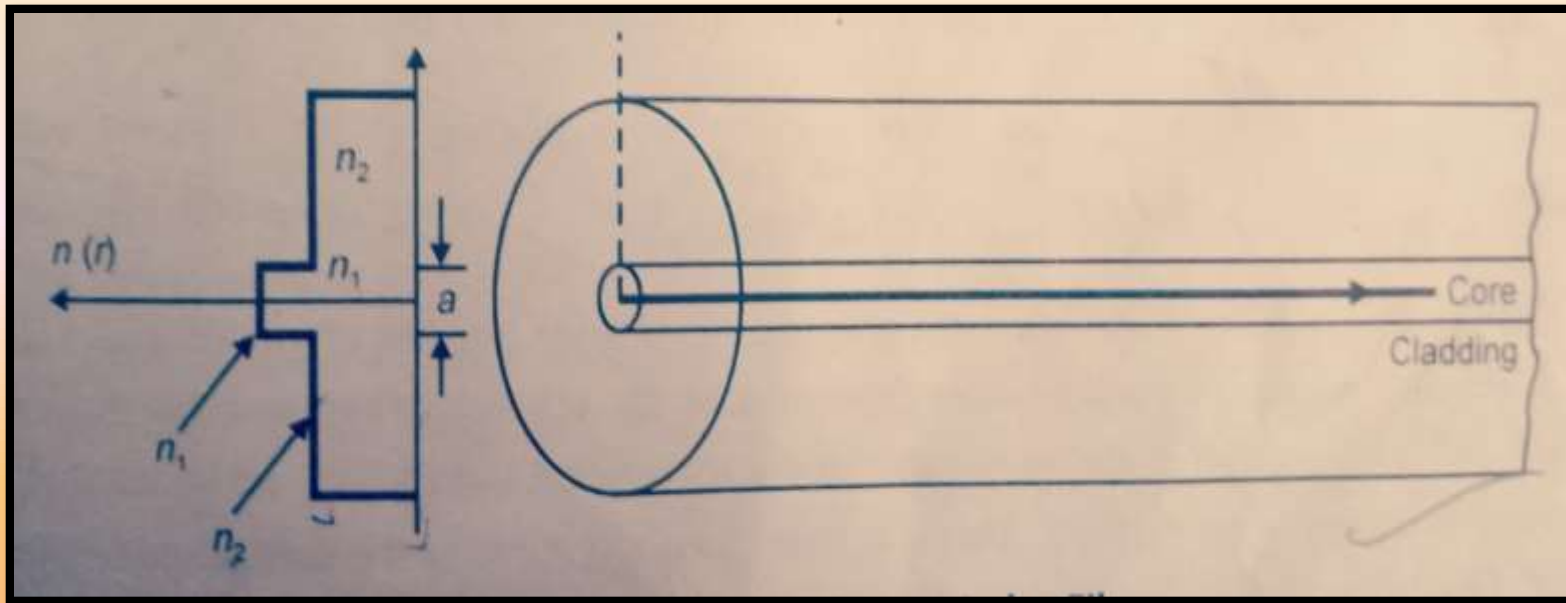

Where

$n(r)$  represents the refractive index

$n_1$  represents the refractive index of core

$n_2$  represents the refractive index of cladding

## (b) Multimode step index fiber =

The core diameter of a multimode step index fiber is around 50 $\mu\text{m}$ . Due to this large core diameter, many modes can propagate within the fiber core. Multimode step index fiber allows the propagation of an infinite number of guided modes along the channel.

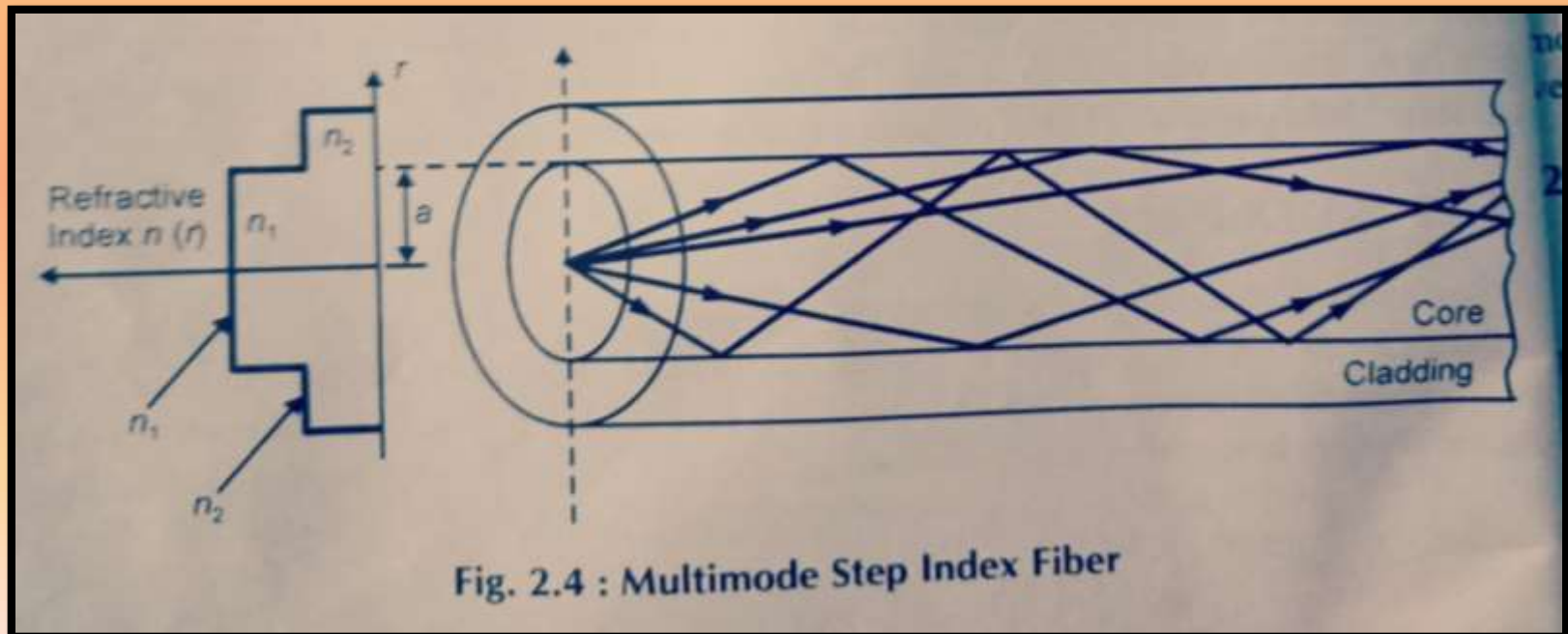

# Advantages of single mode step index fiber over multimode step index fiber

In single mode step index fiber , only one mode can be transmitted at a time along a fiber . Due to this the intermodal dispersion is very low . The signal mode index fiber attains maximum bandwidth during the transmission .

## Advantage of multimode step index fiber over single mode step index fiber

- 1.The coupling of the optical source with the multimode step index fiber is very good .
- 2.The multimode step index fibers have larger numerical apertures and core diameters as compared to single mode step index fiber.
3. The tolerance requirement of fiber connectors is low .

# Graded Index Fiber

Graded index fiber do not have a constant refractive in the core. Graded index refers to the fact that the refractive index of the core gradually decreases farther from the centre of the core .

$$n(r) = \begin{cases} n_1 \left( 1 - 2\Delta \left( \frac{r}{a} \right)^\alpha \right)^{\frac{1}{2}} & r < a \text{ (core)} \\ n_1 (1 - 2\Delta)^{\frac{1}{2}} = n_2 & r \geq a \text{ (cladding)} \end{cases}$$

Here  $\Delta$  represents the relative refractive index difference.

$\alpha$  represents the profile parameter which gives the characteristic refractive index profile the fiber core.  $n_1$  represents the refractive index of the core.

$n_2$  represents the refractive index of the cladding

$a$  represents the core radius.

When  $\alpha = \infty$ , this profile represents a step index profile

When  $\alpha = 2$ , this represents a parabolic profile

When  $\alpha = 1$ , this represents a triangular profile.

# GRADED INDEX FIBER DIAGRAM

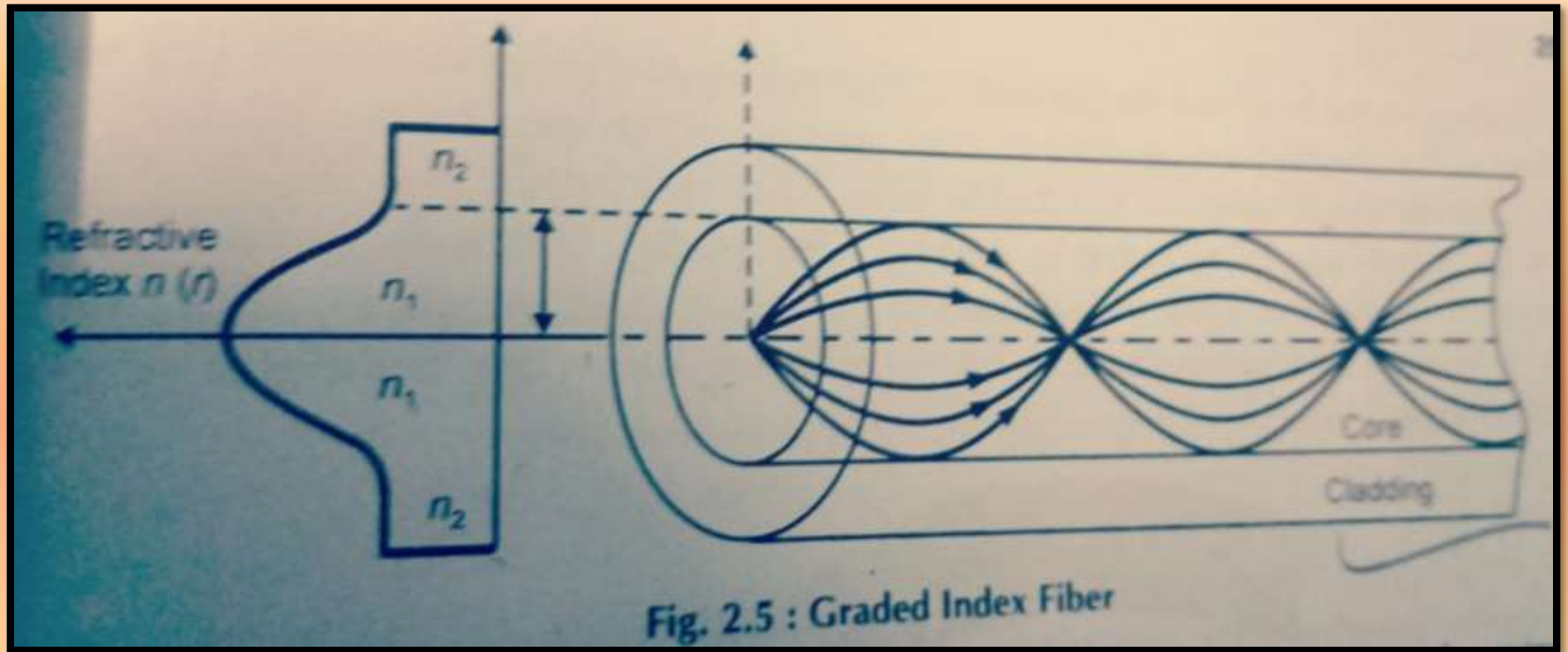

# Multimode and Single-Mode Light Propagation

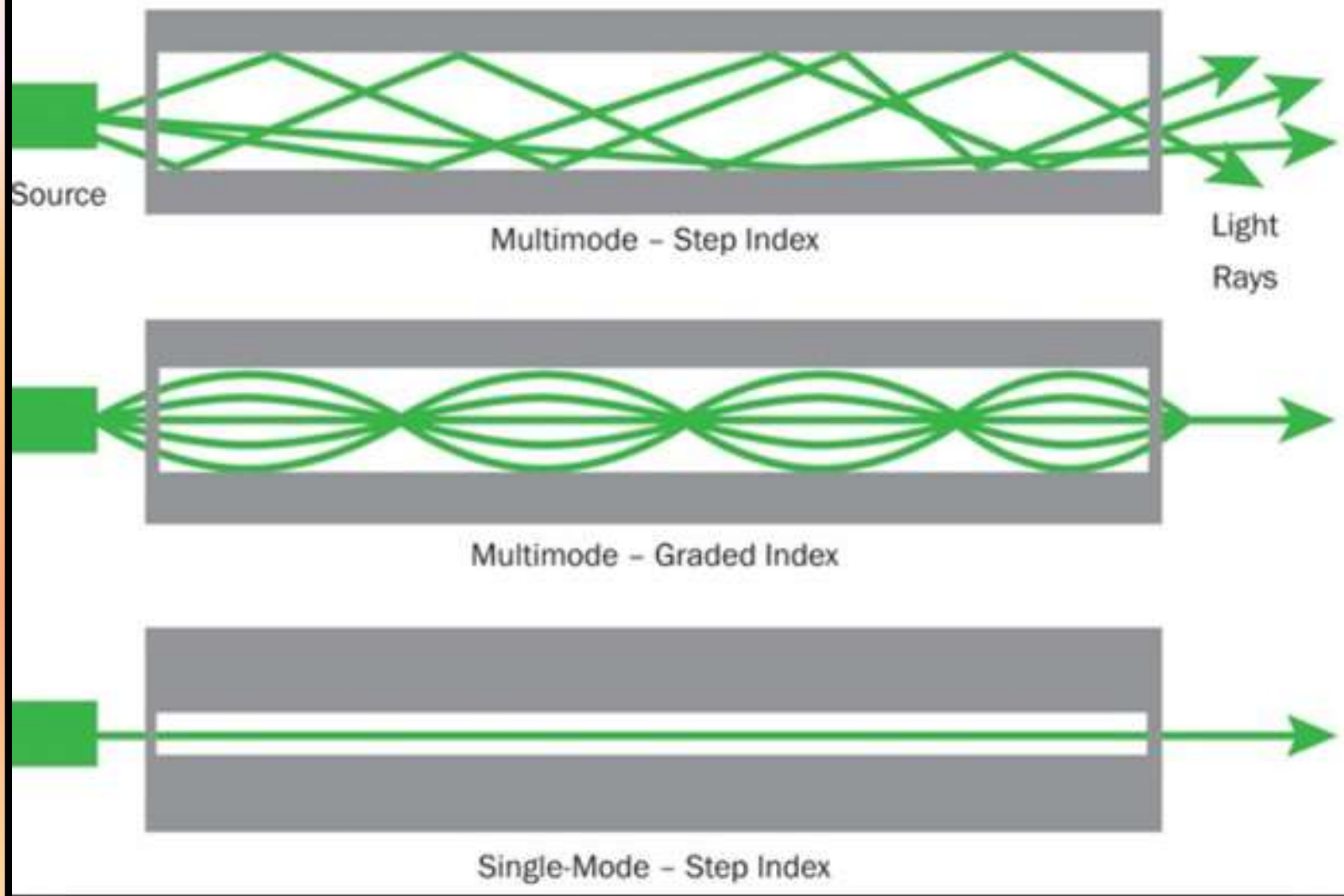

## *Advantages of multimode graded index fiber over multimode step index fiber*

1. Multimode graded index fiber exhibits far less intermodal dispersion as compared to Multimode step index fiber due to their refractive index profile. In graded index fiber, many Different modes are excited at a time and the different group velocity of the modes tends to Be normalized by the index grading. According to ray theory the rays travelling in the outer region of the core have longer path when compared with rays which travel closer to the fiber Axis the near axial rays are transmitted through a region of higher refractive index and so travel with a lower velocity than the more extreme rays. In this ways this phenomenon compensates for the shorter paths length and reduces dispersion in the fiber.

2. Multimode graded index fiber with parabolic profile cores have transmission bandwidth Which may of the order of magnitude greater than the multimode step index fiber so Multimode graded index fiber are used for long distance communication.

## ACCEPTANCE ANGLE

The principle of propagation of light in an optical fiber is total internal reflection, so it is necessary to study that how the light rays enter the fiber. “ if the light rays enter in the fiber with an angle greater than the critical angle at the core cladding interface.

The phenomenon of total internal reflection is achieved but if the angle of incident of the ray is smaller than the critical angle, then the ray will continue to propagate down its length.

# DIFFERENT TYPES OF OPTICAL FIBER CABLES

1. Simple cables are used in controlled environments such as in offices.
2. Non metallic cables.
3. Directly buried type cables. These cable are heavily armoured.
4. Cables are used in underground ducts. The optical fiber cables used in telephone communication is the best example.
5. Overhead cables.
6. Under water cables.

# TYPES OF FIBER CONNECTORS

❖ Basically there are four types of Fiber optic connectors:

- Butt joint.
- Resilient ferrule.
- Grooved plate hybrids.
- Expanded beam.

Lets concentrate on Butt joint and Expanded Beam.



Straight  
sleeve

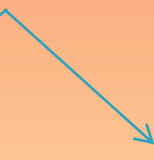

Tapered  
sleeve

# OPTICAL FIBER CONNECTORS

❖ The optical connectors are generally used to **join sources as well as detectors to optical fiber temporarily.**

❖ some of the principal requirements of a good connector design are as follows:

- Low losses
- Interchangeability
- Ease of assembly
- Low environmental sensitivity
- Low-cost and reliable construction
- Ease of connection

# BUTT JOINT CONNECTORS

- Butt joint connectors employ a metal, ceramic or molded plastic ferrule for each fiber and a precision sleeve into which the ferrule fit.
- The fiber is epoxied into a precision hole which has been drilled into the ferrule.
- They are of two type: straight sleeve and tapered sleeve.

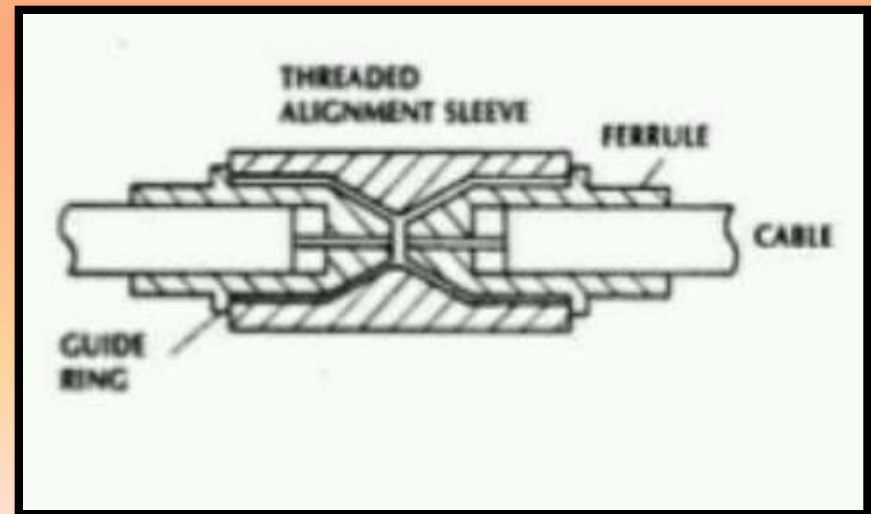
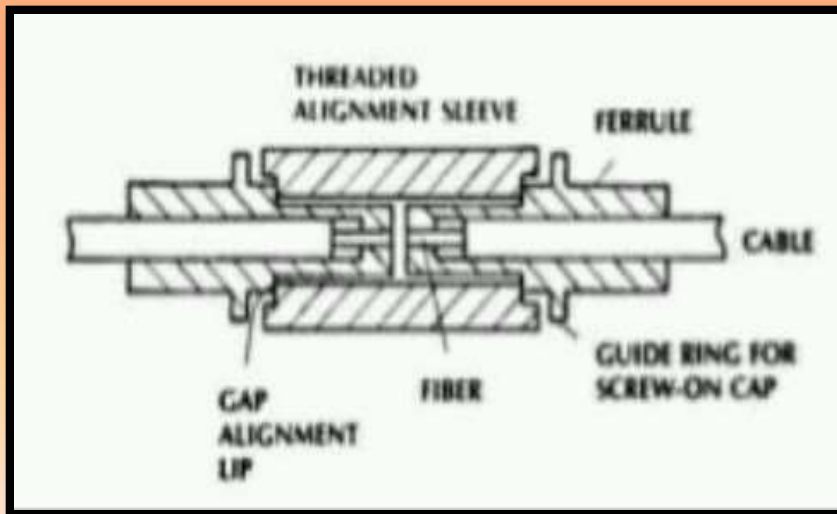

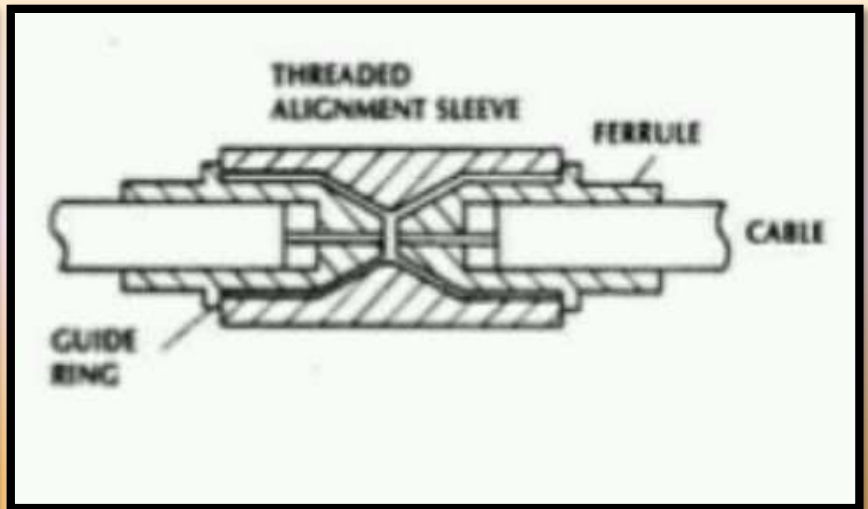
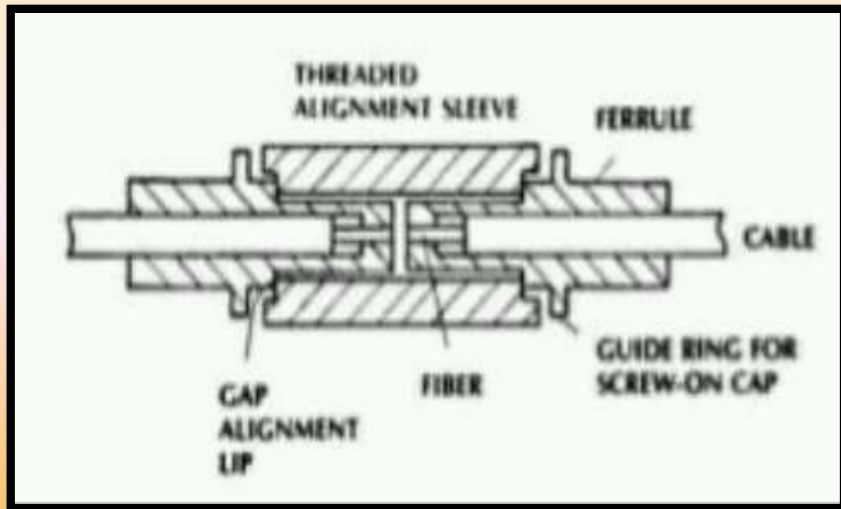

- In straight sleeve connector length of the sleeve and a guide ring on the ferrules determine the end separation of fibers.

- In tapered sleeve ,it uses a tapered sleeve to accept and guide taped ferrules.
- Again the sleeve length and guide rings maintain a given fiber -end separation.

# EXPANDED BEAM CONNECTORS

- It employs lenses on the ends of the fibers.
- These lenses either collimate the light from transmitting fiber or focus the expanded beam onto the core of the receiving fiber .
- Fiber to lens distance = Focal length of lens .

## ❖ ADVANTAGES:

- Connector is less dependent on lateral alignments .
- Beam splitters and switches can be easily inserted into expanded beam between fiber ends.

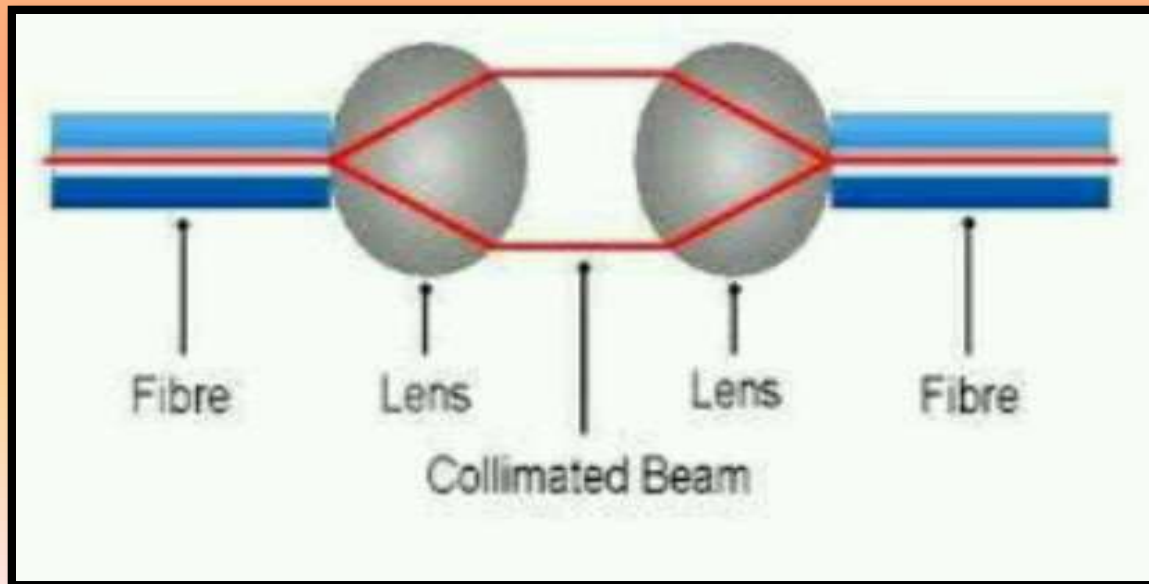

# Fusion and Mechanical Splicing

## Splicing through Fusion:

In fusion type splicing an especially designed machine aligns two separate fiber ends before “welding” or “fusing” them together by means of an electric arc. This mechanism ensures an excellent connection. New splicers available today are capable of handling solo as well as mass fusion operations. Thus, you can proceed with either one fiber or with up to twelve fibers in a single operation.

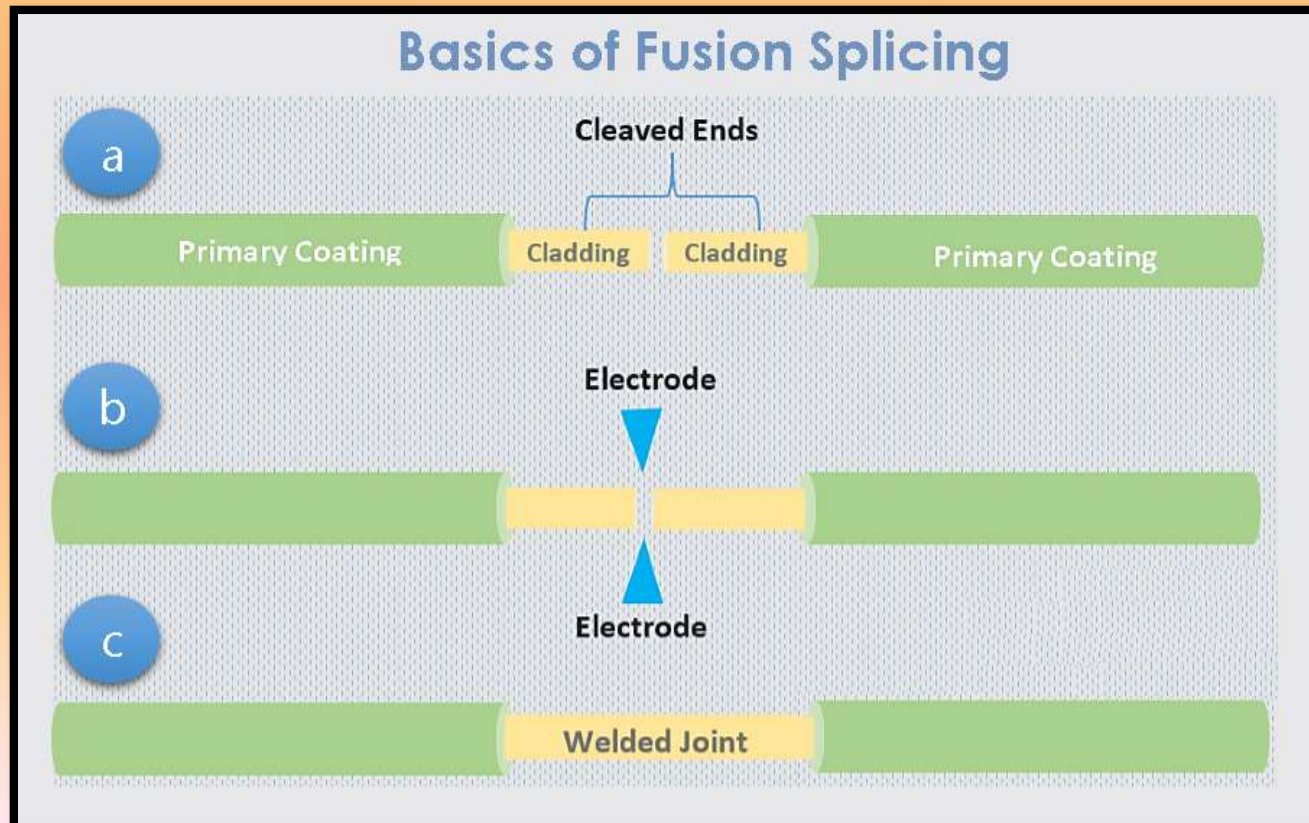

## Mechanical Splicing

In mechanical splicing, the fibers are not coupled permanently. Instead, a uniquely designed self-contained assembly keep the two fibers aligned precisely. Moreover, an appropriate optical adhesive or gel is also used between the fibers. This arrangement enables the light to pass through two separate fiber strands.

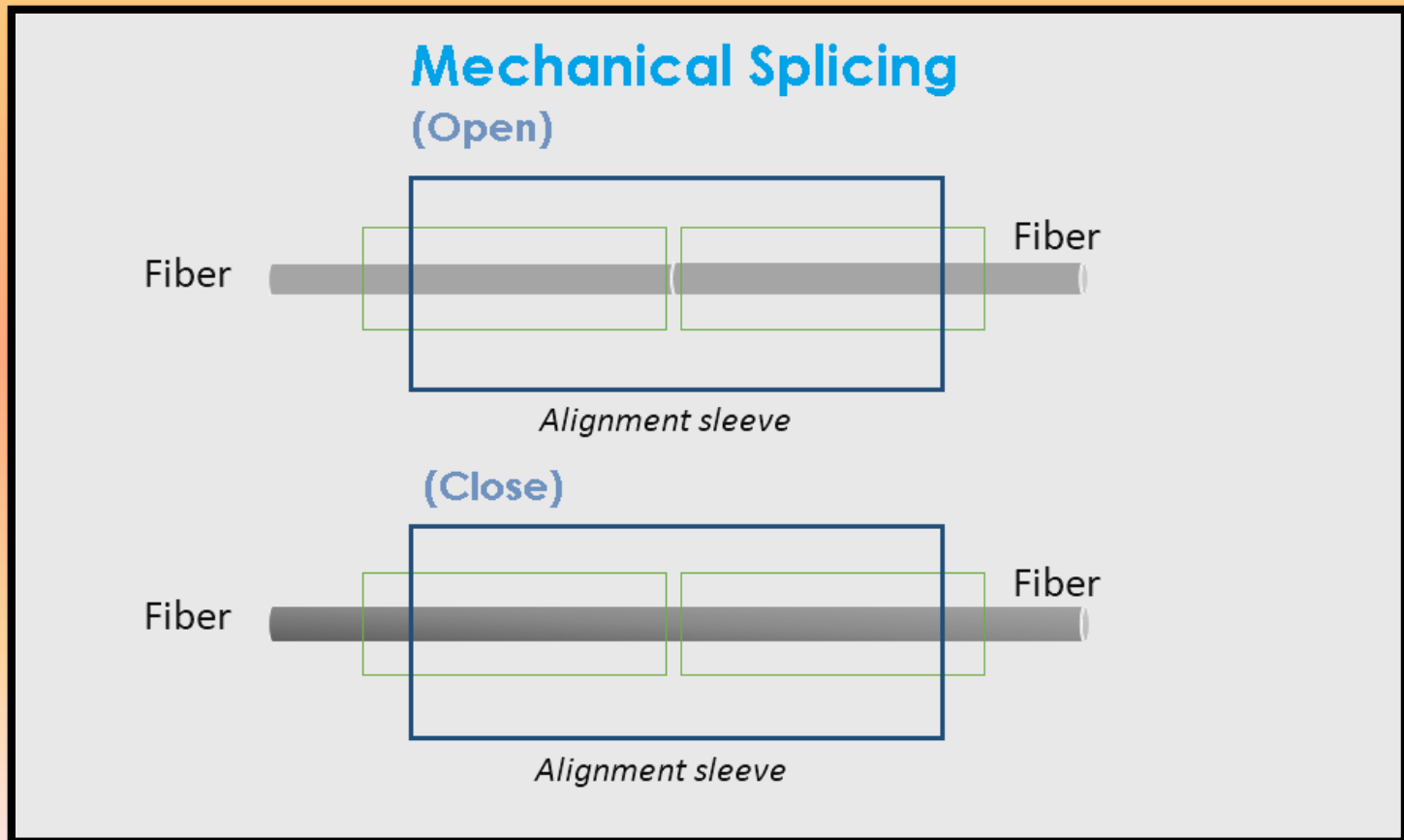

# Fiber Optic Splicing Types

## Mechanical Splicing

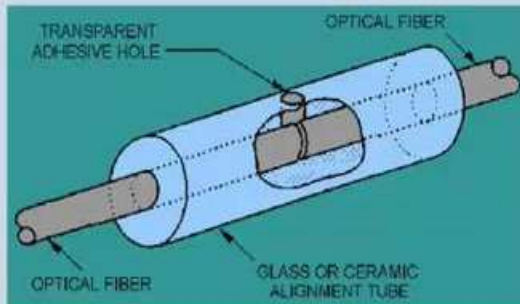

1. Just a mechanical alignment device
2. Holds the two fiber ends in a precisely aligned position
3. Still two separate fibers, NOT continuous

## Fusion Splicing

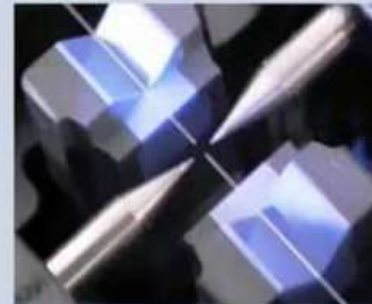

1. Two fiber ends are aligned and then fused or welded together
2. Using heat or electric arc
3. Two fibers become continuous

# UNIT 3: LOSSES IN OPTICAL FIBER

# THE PREDOMINANT LOSSES IN OPTICAL FIBER

The predominant losses in optical fiber are as follows:

1. Absorption losses due to impurities in the fiber material.
2. Material or Rayleigh scattering losses due to microscopic irregularities in the fiber.
3. Chromatic or Wavelength dispersion because of the use of a non-monochromatic source.
4. Radiation losses caused by ends and kinks in the fiber.
5. Modal dispersion or pulse spreading due to rays taking different paths down the fiber.
6. Coupling losses caused by misalignment and imperfect surface finishes.

# ABSORPTION

Absorption is a major cause of signal loss in an optical fiber. Absorption is defined as the portion of attenuation resulting from the conversion of optical power into another energy form, such as heat. Absorption in optical fiber is explained by three factors:

- I. Imperfection in the atomic structure of the fiber material.
- II. The intrinsic or basic fiber- material properties.
- III. The extrinsic (presence of impurities) fiber material properties.

## Absorption Loss

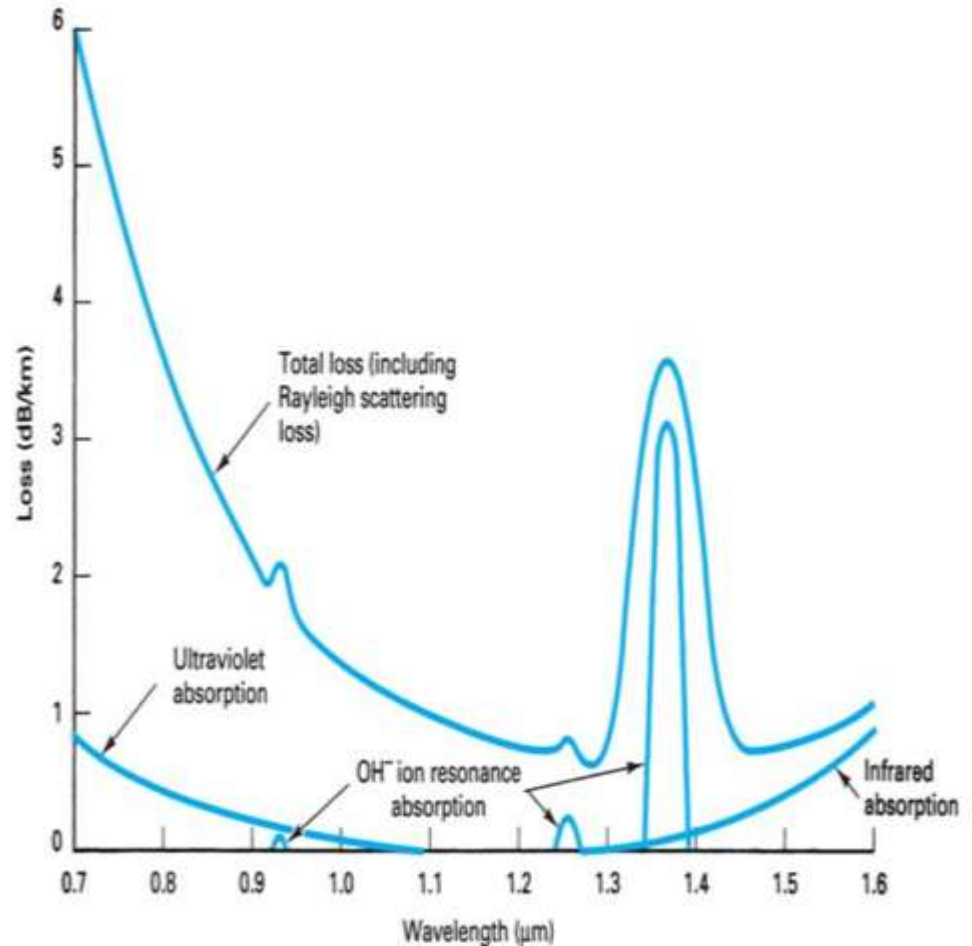

# *Linear Scattering Losses*

1. In this scattering losses, optical fiber transmitted from one mode to another mode linearly. Since, in its linear so there is no change in frequency, the parent/incident signals frequency & scattered/children signal frequencies are same.
2. Linear scattering are of two types:
  - a) Rayleigh scattering and
  - b) Mie scattering

# LOSSES IN OPTICAL FIBER CABLE

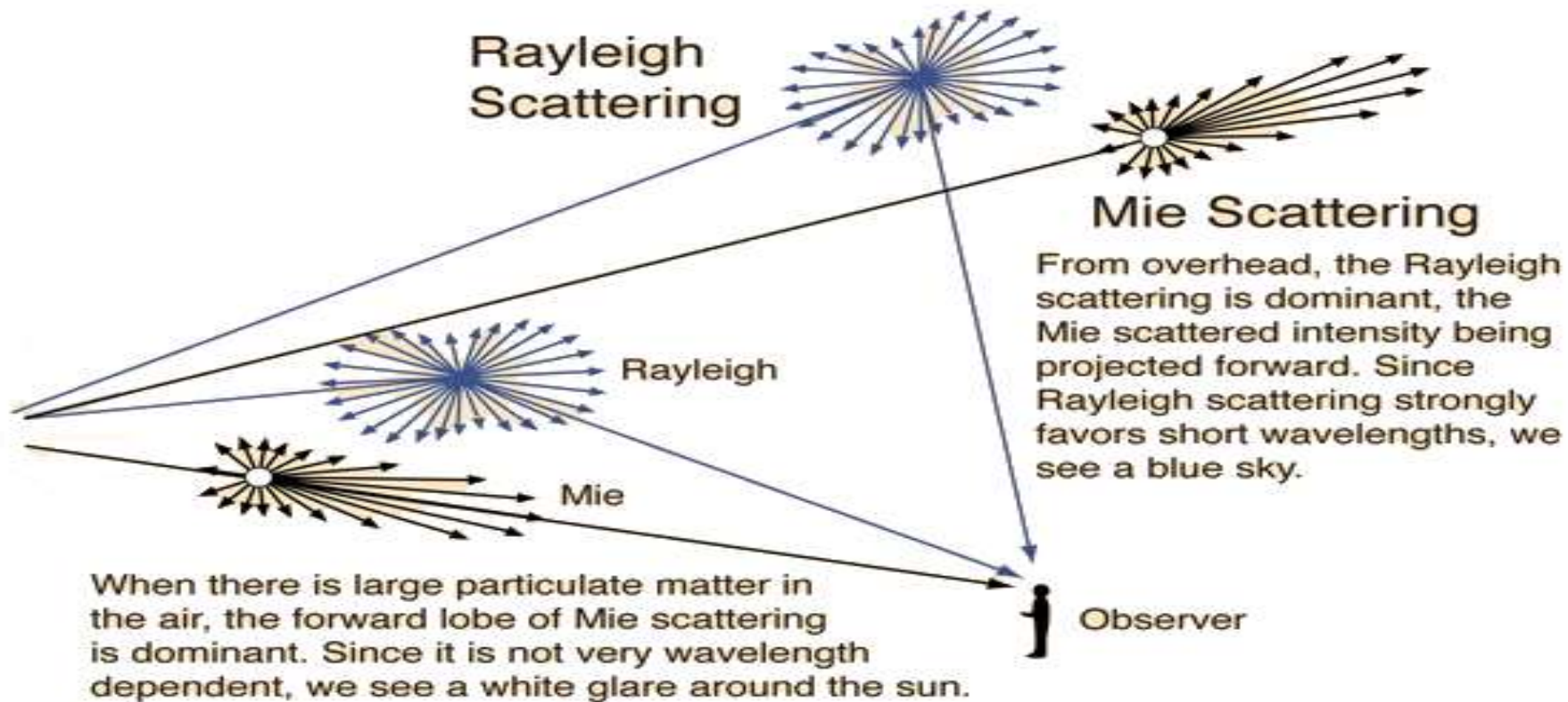

# RAYLEIGH SCATTERING

- ▶ It is a scattering of light by particles much smaller than the wavelength of the light, which may be individual atoms or molecules.
- ▶ CAUSES OF RAYLEIGH SCATTERING
- ▶ The strong wavelength dependence of the scattering ( $\sim\lambda^{-4}$ ) means that shorter (blue) wavelengths are scattered more strongly than longer (red) wavelengths. This results in the indirect blue light coming from all regions of the sky. Rayleigh scattering is a good approximation of the manner in which light scattering occurs within various media for which scattering particles have a small size (parameter).

# MIE SCATTERING

- ▶ Mie scattering (sometimes referred to as a non-molecular or aerosol particle scattering) takes place in the lower 4.5 km of the atmosphere, where there may be many essentially spherical particles present with diameters approximately equal to the size of the wavelength of the incident energy. Mie scattering theory has no upper size limitation, and converges to the limit of geometric optics for large particles.

## ▶ Causes of Mie Scattering

1. Occurred due to inhomogeneities in the composition of silica.
2. Irregularities in the core-cladding interface.
3. Difference in core cladding index
4. Diameter fluctuations
5. Due to the presence of strains and bubbles.

# BENDING LOSSES

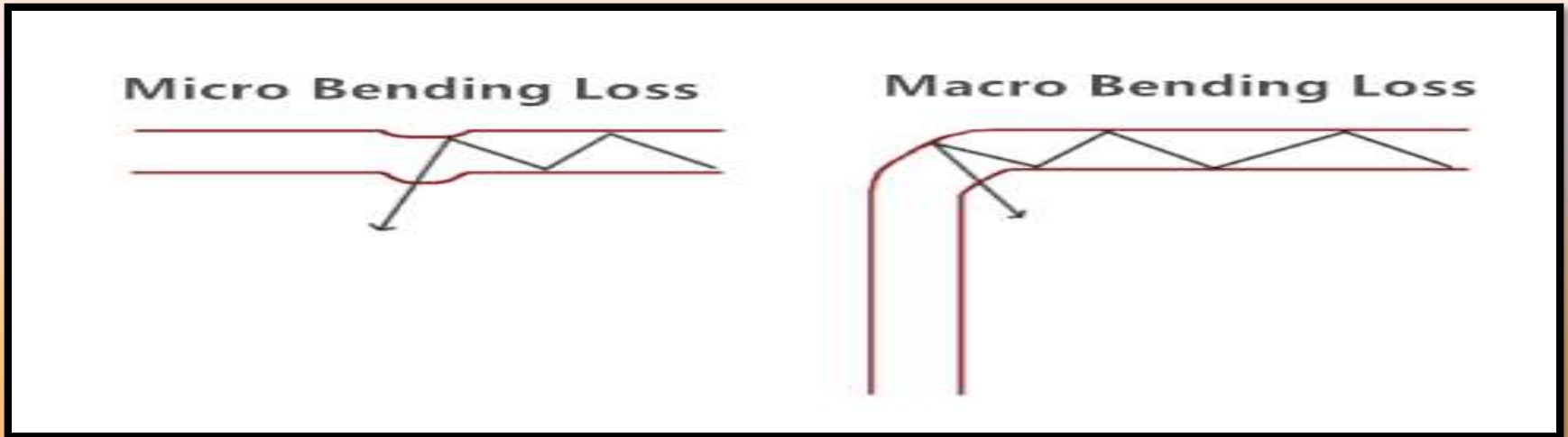

Radiation losses occur whenever an optical fiber undergoes a bend of finite radius of curvature. Fibers can be subject to two types of bend.

- ▶ Macroscopic bends having radii that are large compared to the fiber diameter.
- ▶ Random microscopic bend of the fiber axis that can arise when the fibers are incorporated into cables .
- ▶ Let us examine large curvature radiation losses, which are known as macrobending losses. For slight bend the excess loss is extremely small and is essentially unobservable. As the radius of curvature decrease, the loss increases exponentially until at a certain critical radius the curvature.

Connector Loss sometimes called attenuation, is simply the reduction of **optical** power induced by transmission through a medium such as a pair of **fiber optic connectors**. **Return loss** is the amount of light reflected from a single discontinuity in an **optical fiber** link such as a **connector pair**.

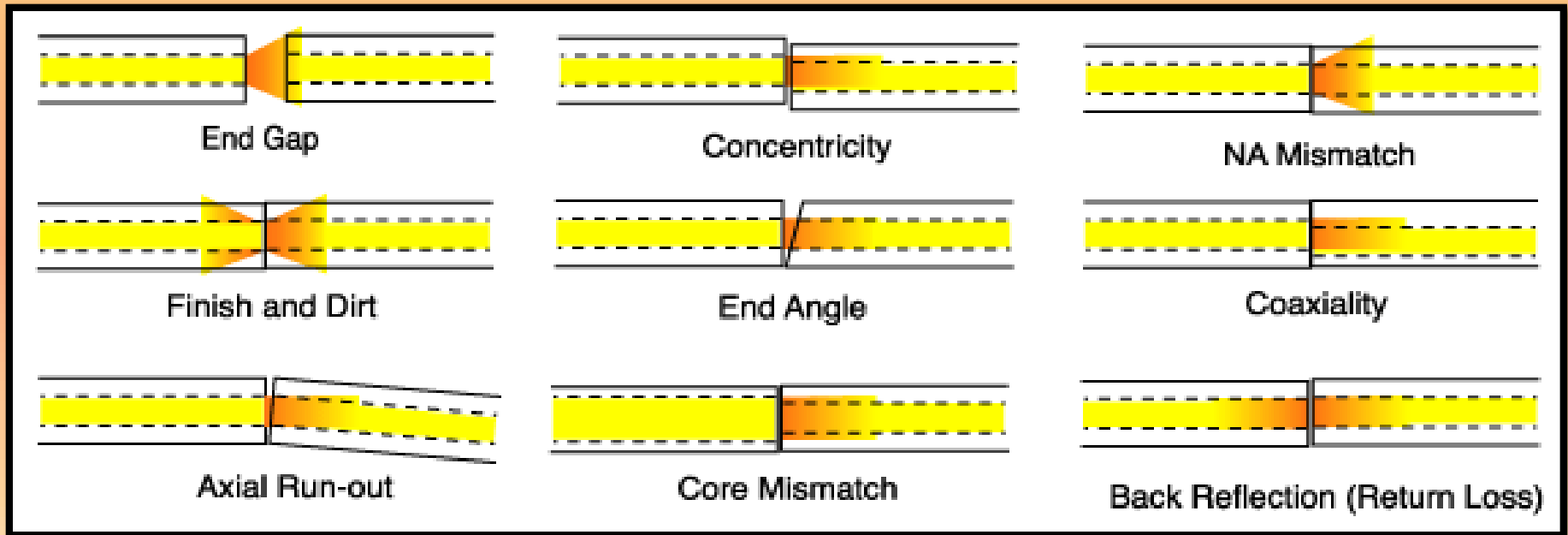

# Dispersion

Dispersion is the spreading of light pulse as its travels down the length of an **optical fiber**. **Dispersion** limits the bandwidth or information carrying capacity of a **fiber**. The bit- rates must be low enough to ensure that pulses are farther apart and therefore the greater **dispersion** can be tolerated.

## **Dispersion**

- **Dispersion** is the spreading of a light pulse.

- **Dispersion limits digital transmission speed** by causing pulses to overlap, so they cannot be distinguished.

The **bit rate** must be low enough to ensure that pulses do not overlap.

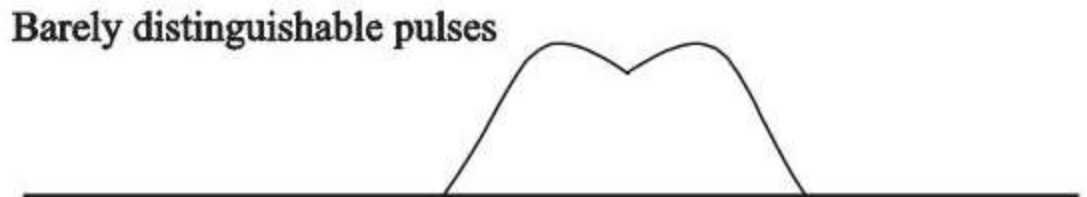
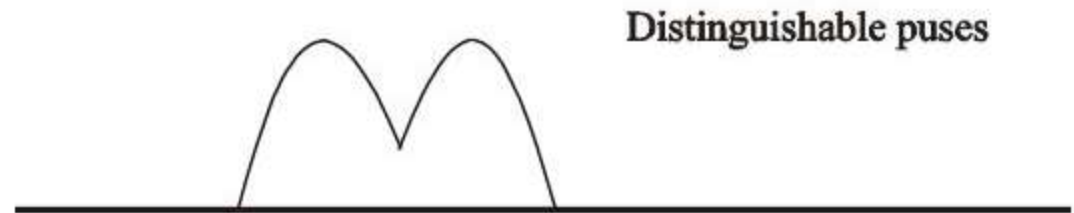
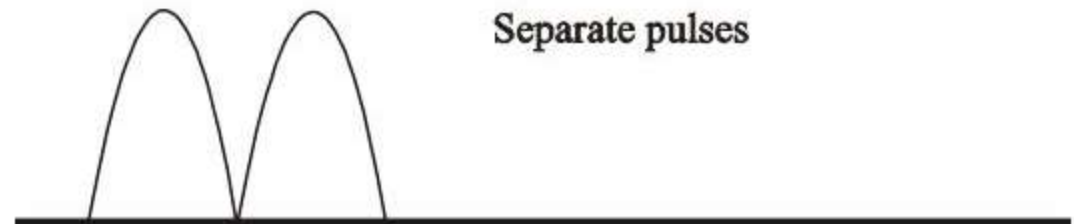

Indistinguishable pulses

## Types of Dispersion:

**Intramodal dispersion** occurs because **different** colors of light travel through **different** materials and **different** waveguide structures at **different** speeds.

**Material dispersion** is caused by a change in **fiber optic** material's refractive index with different wavelength. The higher the index, the slower the light travels.

**Waveguide dispersion** is due to the distribution of light between core and cladding.

**Chromatic dispersion** results from the spectral width of the emitter

### Chromatic Dispersion

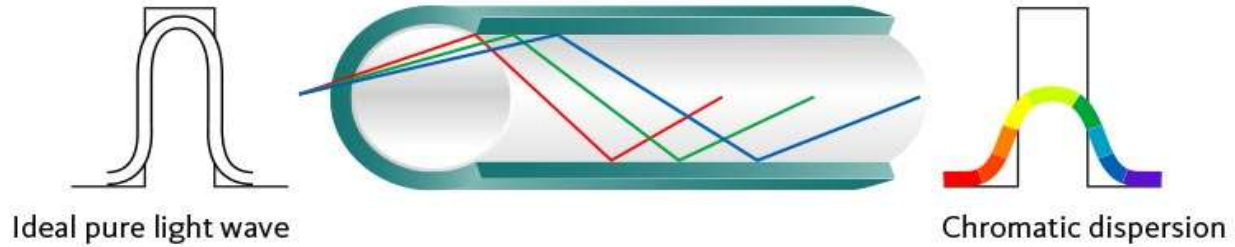

### Modal Dispersion (typical)

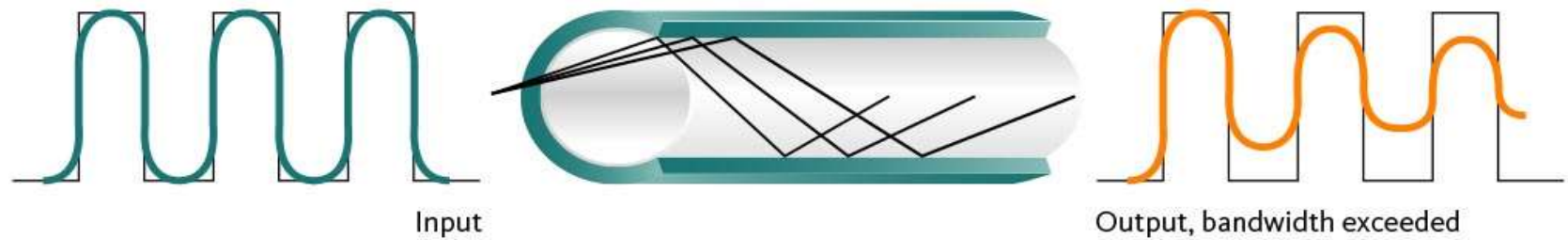

### Modal Dispersion (graded index multimode)

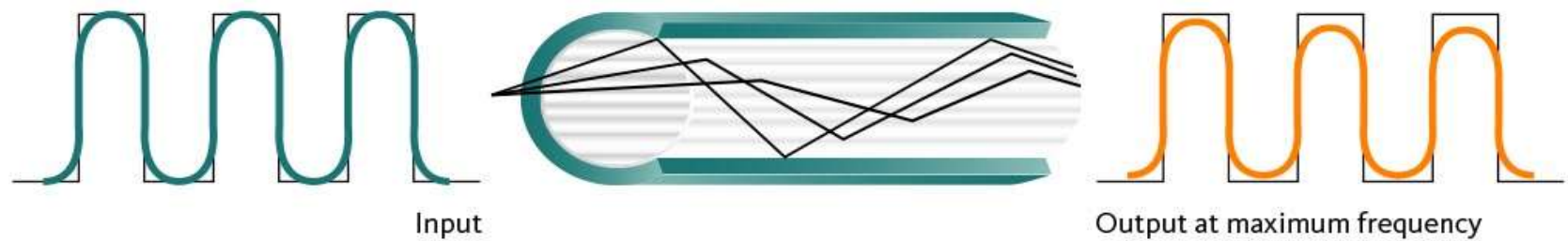

- **Intermodal dispersion:** Different modes propagate at different group velocities.
- **Intramodal or Chromatic Dispersion**
  - ❖ **Material dispersion:** The index of refraction of the medium changes with wavelength.
  - ❖ **Waveguide dispersion:** The index change across waveguide means that different wavelengths have different delays.
- **Polarization mode dispersion:** If waveguide is birefringent. Birefringent is a optical property of a material having a refractive index that depends on the polarization and propagation direction of light.

# INTRA MODAL OR CHROMATIC DISPERSION

- ❑ Different wavelengths travel at different speeds through the fiber
- ❑ This spreads a pulse in an effect named *chromatic dispersion*
- ❑ Chromatic dispersion occurs in both single mode and multimode fiber
- ❑ It is of two types
  - 1) **Material Dispersion** which is wavelength based effect caused by glass of which fiber is made
  - 2) **Waveguide Dispersion** occurs due to change in speed of wave propagating through waveguide

## Waveguide Dispersion

- Arises because a **Single Mode Fiber confines only 80% of the optical power to the core**
- The other **20% tends to travel through the cladding** and hence travels faster
- This results in **spreading** of the light pulses
- The amount of dispersion depends on the **fiber design** and the size of the fiber core relative to the wavelength of operation
- In multimode fibers, waveguide dispersion and material dispersion are basically separate properties.
- **Multimode waveguide dispersion is generally small** compared to material dispersion and is usually neglected.

## Intermodal Dispersion

- In a multimode fiber different modes travel at different velocities.
- If a pulse is constituted from different modes then intermodal dispersion occurs.
- Modal dispersion is greatest in multimode step index fibers.
- The more modes the greater the modal dispersion.
- Typical bandwidth of a step index fiber may be as low as 10 MHz over 1 km.

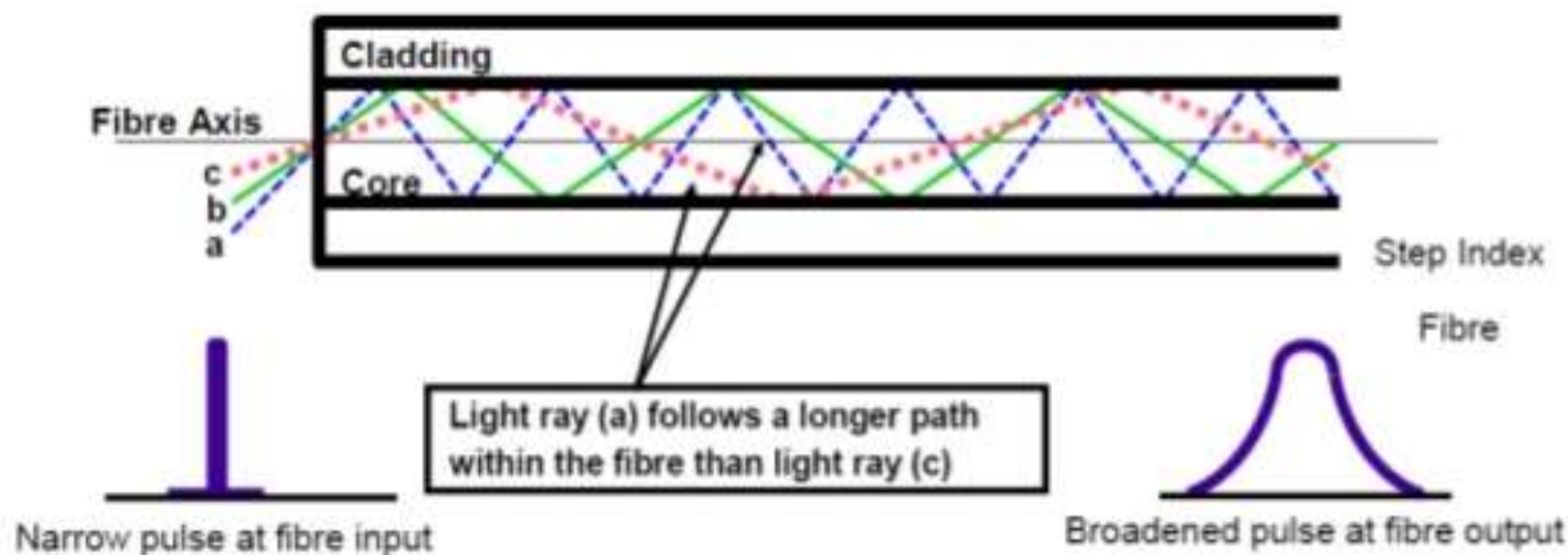

# Intermodal Dispersion

- It can be reduced by using a graded-index profile in the fiber core.
- This allows graded-index fibers to have much larger band-widths (data rate transmission capabilities) than step-index fibers.
- Even higher bandwidths are possible in single-mode fibers, where intermodal dispersion effects are not present.

The Optical Time Domain Reflectometer (OTDR) is useful for **testing** the integrity of fiber optic cables. It can verify splice loss, measure length and find faults. The **OTDR** is also commonly used to create a "picture" of fiber optic cable when it is newly installed.

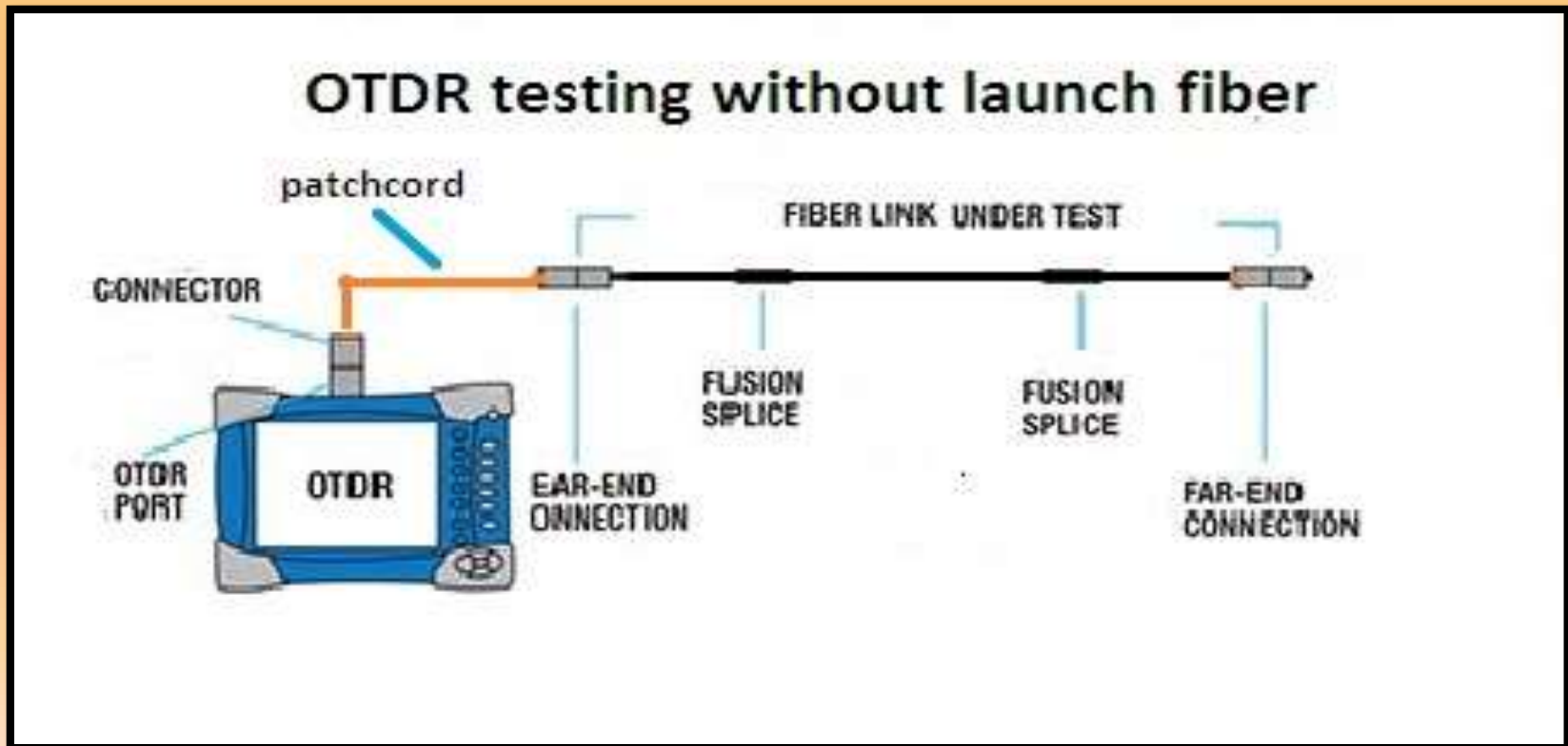

OTDRs are most effective when testing long cables (more than approximately 250 meters or 800 feet) or cable plants with splices. The data that the OTDR produces are typically used to create a picture called a "trace" or "signature" that has valuable information for the trained user and can be stored for later reference or to check against a blueprint when network trouble arises. OTDRs should not be used for measuring insertion loss in the fiber optic cable – that task is better left to a fiber optic test source and power meter. OTDRs simply show you where the cables are terminated and confirm the quality of the fibers, connections and splices

**How Does an OTDR Work?** Unlike sources and power meters which measure the loss of the fiber optic cable plant directly, the OTDR works indirectly. The source and meter duplicate the transmitter and receiver of the fiber optic transmission link, so the measurement correlates well with actual system loss. The OTDR, however, uses a unique optical phenomena of fiber to indirectly measure loss.

The biggest factor in optical fiber loss is scattering. In fiber, light is scattered in all directions, including some scattered back toward the source as shown here. The OTDR uses this "backscattered light" to make measurements along with reflected light from connectors or cleaved fiber end.

The OTDR consists of a high power laser transmitter that sends a pulse of light down the fiber. Back-scattered light and reflected light returns to the OTDR through the fiber and is directed to a sensitive receiver through a coupler in the OTDR front end. For each measurement, the OTDR sends out a very high power pulse and measures the light coming back over time.

At any point in time, the light the OTDR sees is the light scattered from the pulse passing through a region of the fiber. Think of the OTDR pulse as being a "virtual source" created by the scattering that is testing all the fiber between itself and the OTDR as it moves down the fiber.

Since it is possible to calibrate the speed of the pulse as it passes down the fiber from the index of refraction of the glass in the core of the fiber, the OTDR can correlate what it sees in backscattered light with an actual location in the fiber. Thus it can create a display of the amount of backscattered light at any point in the fiber along its length.

# *UNIT 4: OPTICAL SOURCES*

## *LED & LASERS*

1. Advantages of LED
2. Different types of LED
3. LED structures
4. LED characteristics



# Characteristics of light sources

---

- To couple large amounts of power, size and configuration of sources should be compatible with an optical fiber
- Must accurately track the electrical signal to minimize distortion and noise
- Source should emit light at wavelengths where the fiber has low loss, low dispersion, and detectors are efficient
- Modulation bandwidth should be wide
- It should have sufficient optical power
- Output spectrum should be narrow (Narrow linewidth)
- Optical power should be unaffected by changes in ambient conditions
- Source should be comparatively cheap and highly reliable

- Size and configuration compatible with launching light into the fiber( light should be highly directional)
- Should be linear (accurately track the electrical input signal ,minimize the distortion & noise)
- Emit light at wavelengths where fiber has low losses, dispersion and where detectors are efficient
- Capable of simple signal modulation (direct modulation) ranging from audio frequencies to GHz range
- Should couple sufficient optical power to overcome attenuation in the fiber

# LED(LIGHT EMITTING DIODE)

## INTRODUCTION

**“A LED is light emitting semi conductor PN junction which emits light when it is forward biased, by the process of spontaneous emission”.**

**Gallium Arsanide phosphide (Ga As P) and Aluminum Gallium Arsanide (Al Ga As) are materials are commonly used for fabricating the LED, for operation in the shorter wavelength region.**

**The IN GA AS P (Indium Gallium Arsanide Phosphide)materials are used for longer wavelength operation.**

# A Light-Emitting Diode (LED)

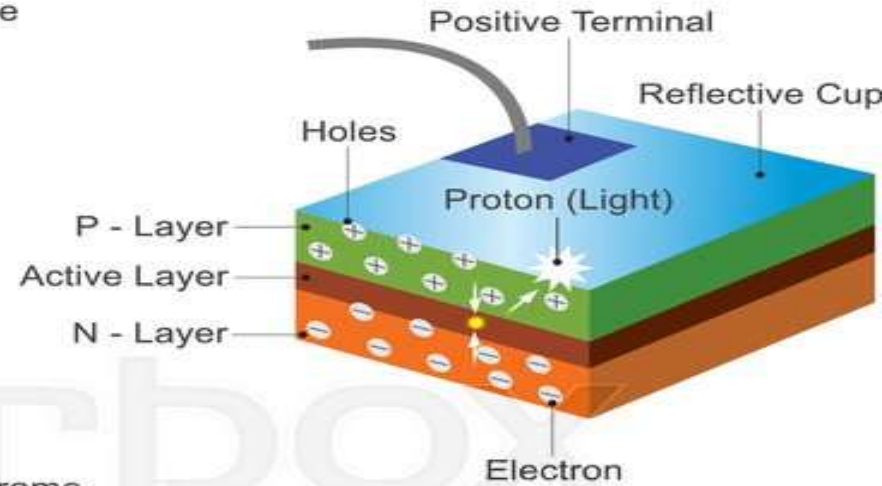
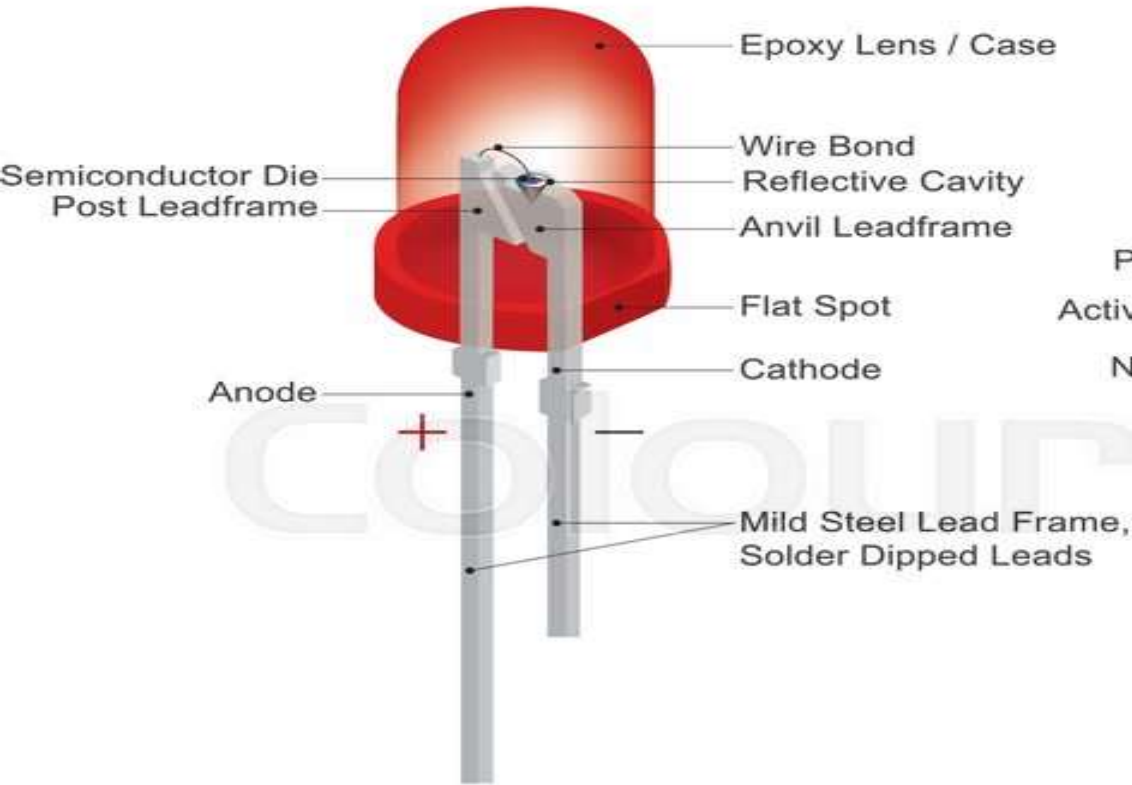

LED Construction

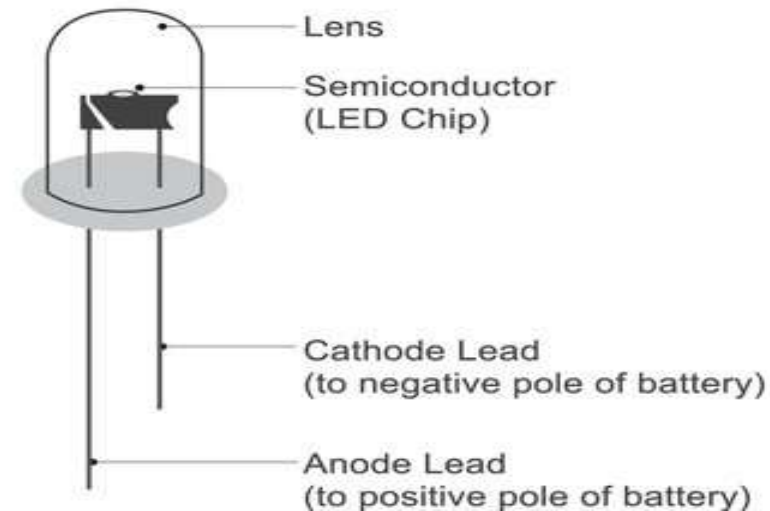
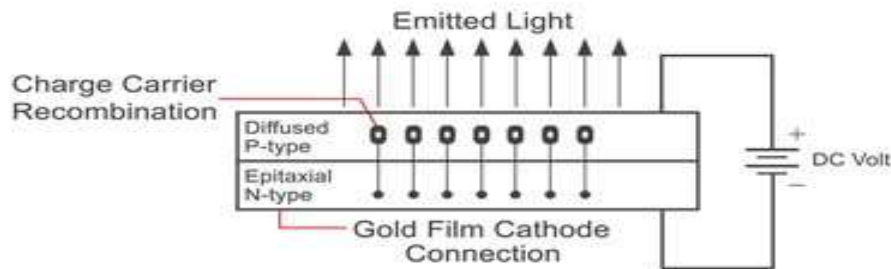

# ADVANTAGES OF LED

- ❑ **Easy Fabrication** : No reflecting faces are required due to absence of stimulated emission. So, simple steps are required in fabrication of LED.
- ❑ **Reliability** : LED is less sensitive to gradual degradation . Therefore LED have much longer life time than ILD (Injection Laser Diode).
- ❑ **Cost** : Simple fabrication process results in reduced cost, which is always desirable.
- ❑ **Drive Circuitry** : LEDs are less sensitive to temperature. So no need to employ temperature compensation circuits resulting simple drive circuitry.
- ❑ **Linear Characteristics** : LED has a linear light output against current.

# DIFFERENT TYPES OF LED'S

We have considered the photo emissive properties of a p-n junction fabricated from a single crystal semi conductor material. Such a LED is known as homojunction LED.

LEDs produced light which is emitted in all junction and their internal quantum efficiency is small. The ratio of electrical energy converted into light is very small.

radioactive properties of a junction diode may be improved by using hetrojunction structure instead of homojunction structures are classified in to two types :-

1. isotope(n-n or p-p)
2. Anisotype(p-n)

Isotype heterojunction provides a potential barrier within the structure. It helps for the confinement of minority carriers to a small region. Carrier diffusion length is reduced

Effective & thus area where radiative recombination may take place. This technique is widely used for fabrication of high radiance LEDs.

Anisotype heterojunction structure is designed using materials with large bandgap differences to improve the junction efficiency. A dielectric step is due to different refractive indices at either side of the junction. It provides radiation confinement to the active region.

# DOUBLE HETEROJUNCTION STRUCTURE : ( DH - LED )

“double heterojunction LED consists of a p-type GaAs layer sandwiched between a p-type AlGaAs and n-type AlGaAs layer” .

It is formed when a layer of material with particular band gap energy is sandwiched with a layer of material having higher band gap energy. This is called double heterojunction because there are two heterojunctions placed on each side of the active material.

The device shown consists of a P-type GaAs layer sandwiched between a P-type AlGaAs and n-type AlGaAs Layer.

When a forward bias is applied electrons from the n-type layer are injected through the p-n junction into the p-type GaAs Layer where they become minority carriers.

These minority carriers diffuse away from the junction, recombining with majority carriers as they do.

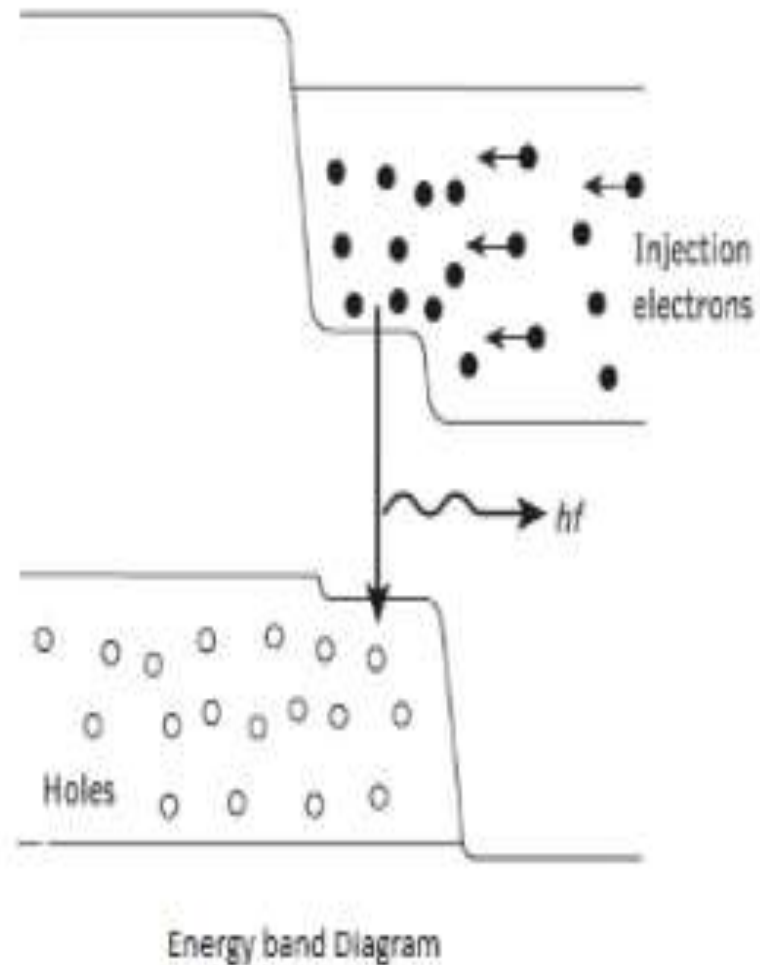
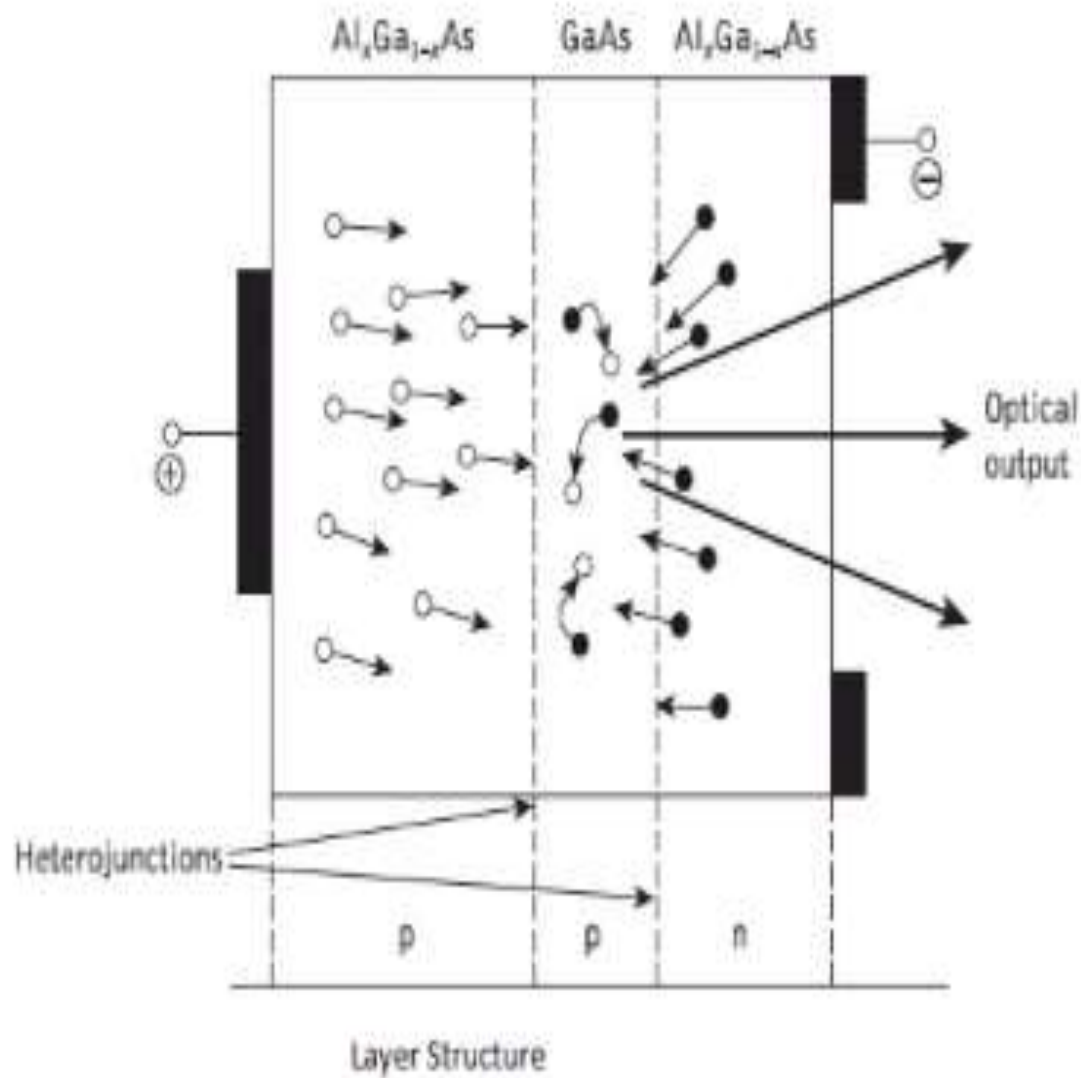

Figure 3.1: Double heterojunction Structure

Photons are therefore produced with energy corresponding to the bandgap energy of the p-type GaAs layer.

The injected electrons are inhibited from diffusing into the p-type AlGaAs layer because of the potential barrier presented by the p-p heterojunction.

Therefore the DH structure provides the most efficient incoherent sources for application.

### Limitations of Double heterojunction LED:

It comes from the very small potential barrier that an electron, in the conduction band, encounters when it reaches the p-side of the junction.

They are only usable at low temperatures.

# LED STRUCTURE

*There are five major type of LEDs structures*

Only two types ( surface emitter and edge emitter ) are extensively used in optical fiber communication. Other three types are :-

- 1 super luminescent LED
- 2 planar LED
- 3 DOME LED

## PLANAR LED

It is the simplest structure which is fabricated over a Ga As substrate using liquid /

Vapour phase epitaxial process. This involves a diffusion of p - type material into

N-type substrate to create a p-n junctions illustrated. Forward biasing of pn junction

gives spontaneous emission and device emits light from all surfaces.

- ▶ The planar LED is the simplest of the structures that are available and is fabricated by either liquid- or vapor-phase epitaxial processes over the whole surface of a GaAs substrate.

This involves a *p-type diffusion into the n-type substrate in order to create the junction* illustrated in Figure.

Forward current flow through the junction gives Lambertian spontaneous emission and the device emits light from all surfaces.

However, only a limited amount of light escapes the structure due to total internal reflection and therefore the radiance is low.

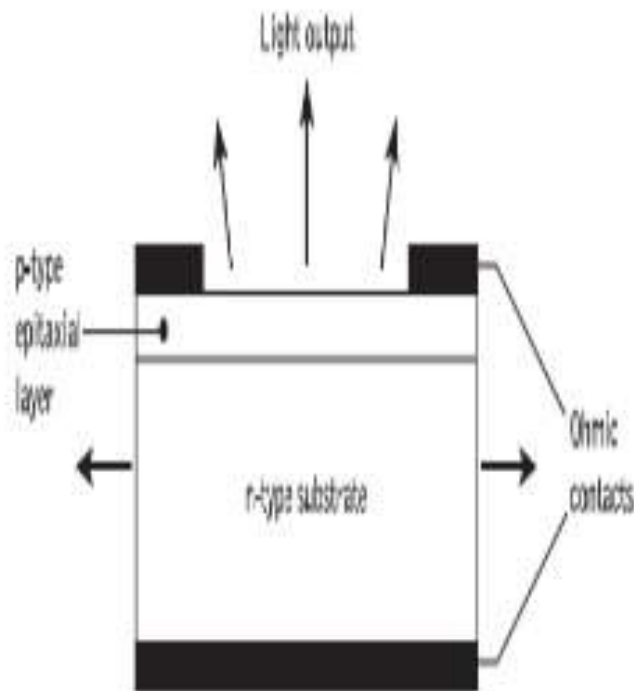

# DOME LED

A half sphere ( hemisphere ) of n-type Ga As is formed around p type region. The diameter of done is designed to maximize the amount of internal emission. Hence , this LED gives a high power efficiency than planar LED.

- ▶ The structure of a typical dome LED is shown in Figure.
- ▶ A hemisphere of *n-type GaAs* is formed around a diffused *p-type region*.
- ▶ *The diameter of the dome is chosen to maximize of internal emission reaching the the critical angle of the GaAs-air*

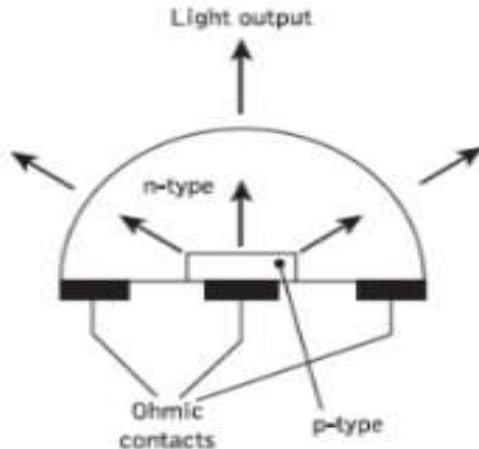

device has a higher external power than the planar LED.

The geometry of the structure is such that the diameter must be far larger than the active area, which gives a greater effective area and thus reduces the radiance.

Dome LED

# SURFACE EMITTER LED (BURRUS TYPE )

Burrus type LED gives high radiance ( light output ) with in a small active region. These structure have a low thermal impedance allowing large current and therefore high radiation emission in to the fiber connected to it. However, the performance may be improved further by employing DH structures. This type of surface emitter light emitting diode (SLED) is widely used in optical fiber communications.

The structure of high radiance etched DH surface emitter for 0.8 to 0.9  $\mu$ m wavelength.

The surface-emitting LED is also known as the Burrus LED in honor of C. A. Burrus, its developer. In SLEDs, the size of the primary active region is limited to a small circular area of 20  $\mu$ m to 50  $\mu$ m in diameter. The active region is the portion of the LED where photons are emitted. The primary active region is below the surface of the semiconductor substrate perpendicular to the axis of the fiber.

# Burrus type surface emitting LED (SLED)

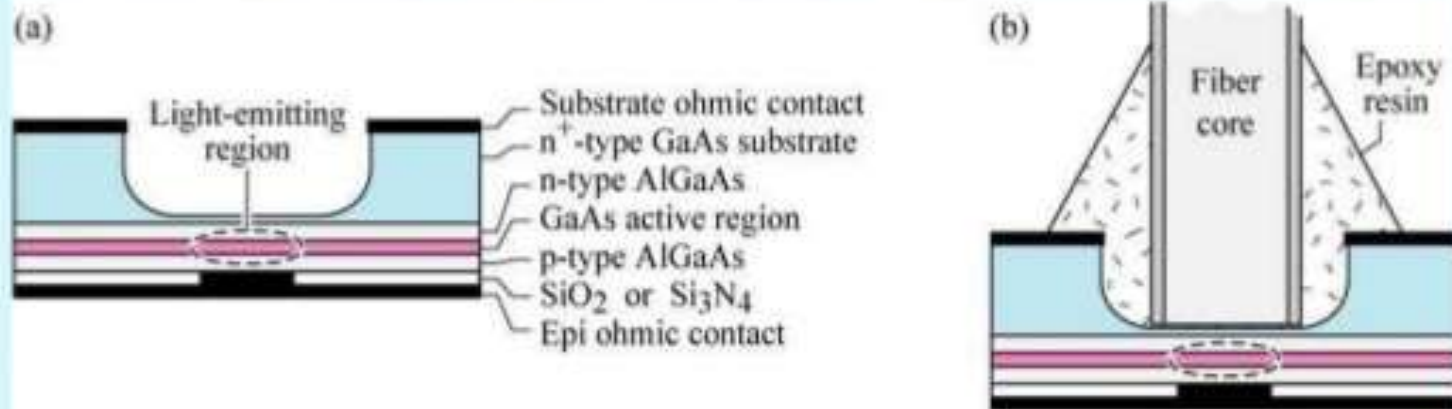

(a) Burrus-type  $\text{Al}_x\text{Ga}_{1-x}\text{As}/\text{GaAs}$  DH LED with the opaque GaAs substrate removed above the active region by wet chemical etching. The Burrus-type LED is mounted substrate-side up. (b) Optical fiber coupled to a Burrus-type LED.

# EDGE EMITTER LEDs

Edge emitter LED is a high radiance structure used in output communication. The DH structure provides optical confinement in vertical direction. A light-emitting diode with output that emanates from between the heterogeneous layers. It has greater radiance and coupling efficiency to an optical fiber or integrated optical circuit than a surface-emitting LED, but not as great as the injection laser.

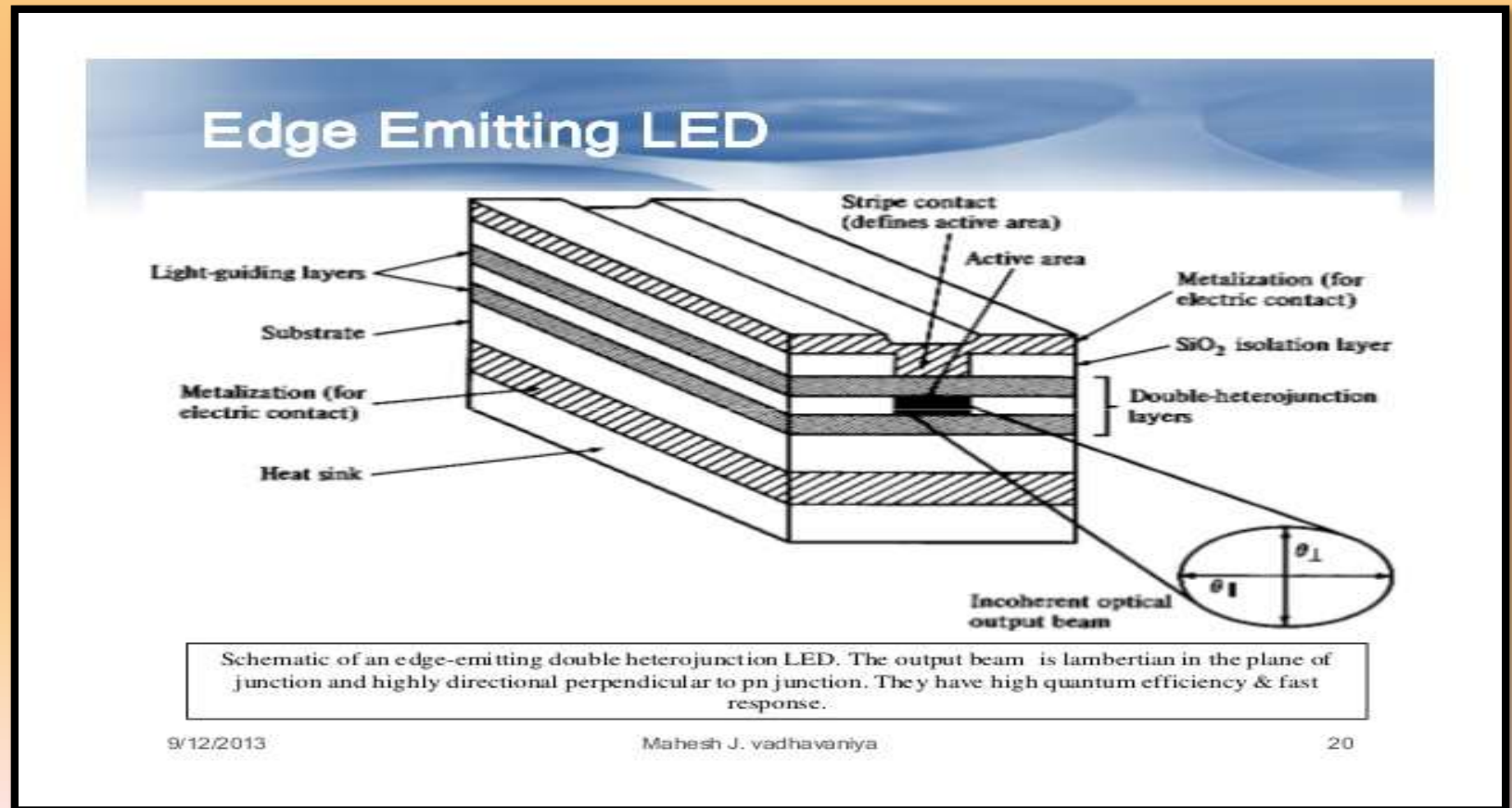

SR No.	SLED	ELED
1.	Easy to fabricate	Difficult to fabricate
2.	Easy to mount and handle	Difficult to mount and handle
3.	Require less critical tolerances	Need critical tolerance on fabrication
4.	Less Reliable	Highly reliable
5.	Low system performance	High system performance
6.	Less modulation Bandwidth	Better Modulation, Bandwidth of the order of hundreds of MHz
7.	Couple less optical power into low NA fiber	Couple more optical power into low NA fiber
8.	Light is emitted from the surface of active Layer	Light is emitted from edge of active Layer
9.	Wider spectral width	Narrow spectral width
10.	Maximum quantum efficiency is up to 60%	Internal quantum efficiency is in the range of 60% to 80%

# SUPERLUMINESCENT LED (SLD)

Superluminescent LED provides significant benefits over SLEDs ELEDs for communication. This devices offers following :-

- 1 high power output
- 2 directional beam output
- 3 narrow spectral line width

The potential drawbacks associated with SLDs

- 1 non-linear output
- 2 increased temperature dependence

# LED CHARACTERISTICS

## OPTICAL POWER Vs CURRENT

Ideally, LED is a linear device. Therefore it is most suitable for analog transmission. However, LEDs in practice exhibit significant non-linearities. The use of linearization circuit is done to ensure the linear performance of device.

The light output against current characteristics for typically surface and edge emitters respectively.

The surface emitter gives more optical power in to air than edge emitter and both devices are reasonably linear at moderate drive currents.

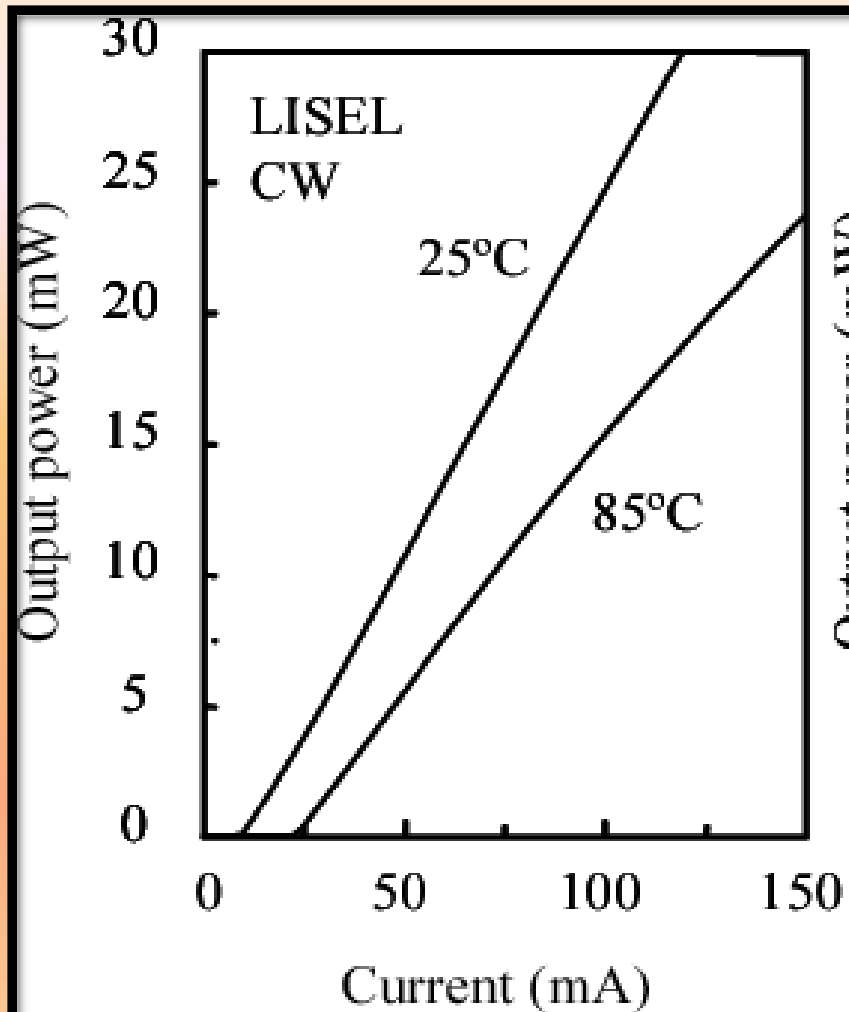

(a)

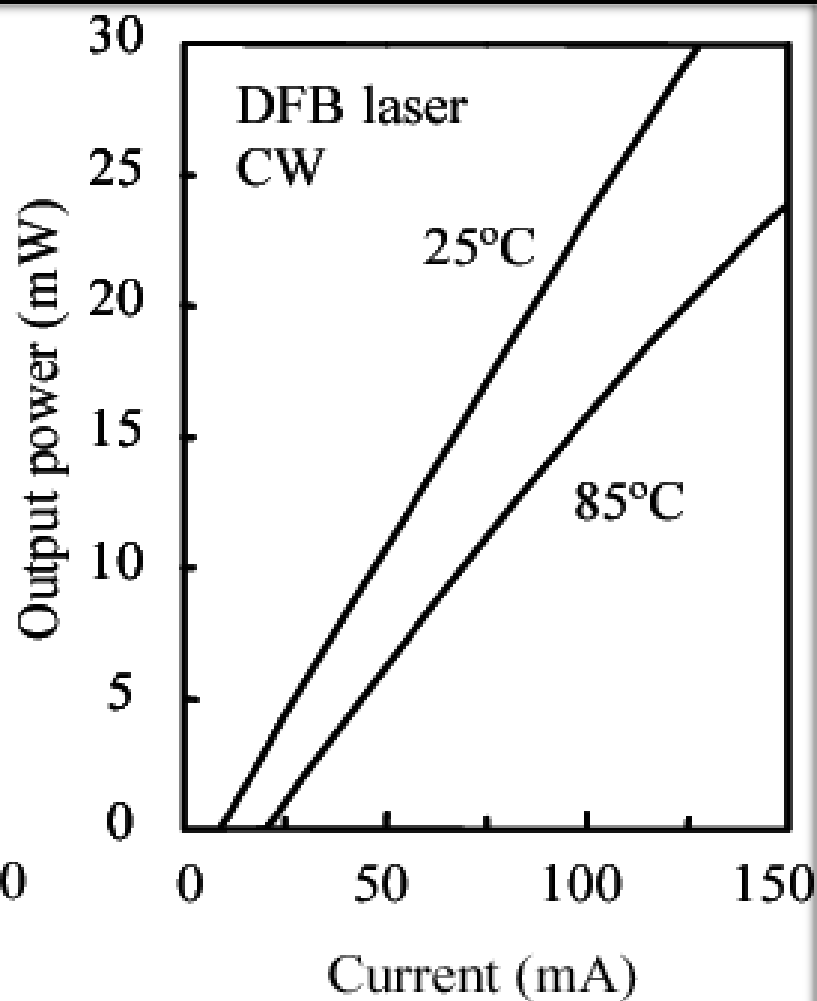

(b)

# ***LIGHT ( OPTICAL) POWER VS TEMPERATURE***

The internal quantum efficiency of LEDs decreases exponentially with increasing Temperature. Hence the light emitter from these devices decreases as the temperature of pn junction increase. Light emitter by different LEDs against temperature.

The characteristics curve shows the variations in optical power output at a specific drive current over different temperature.

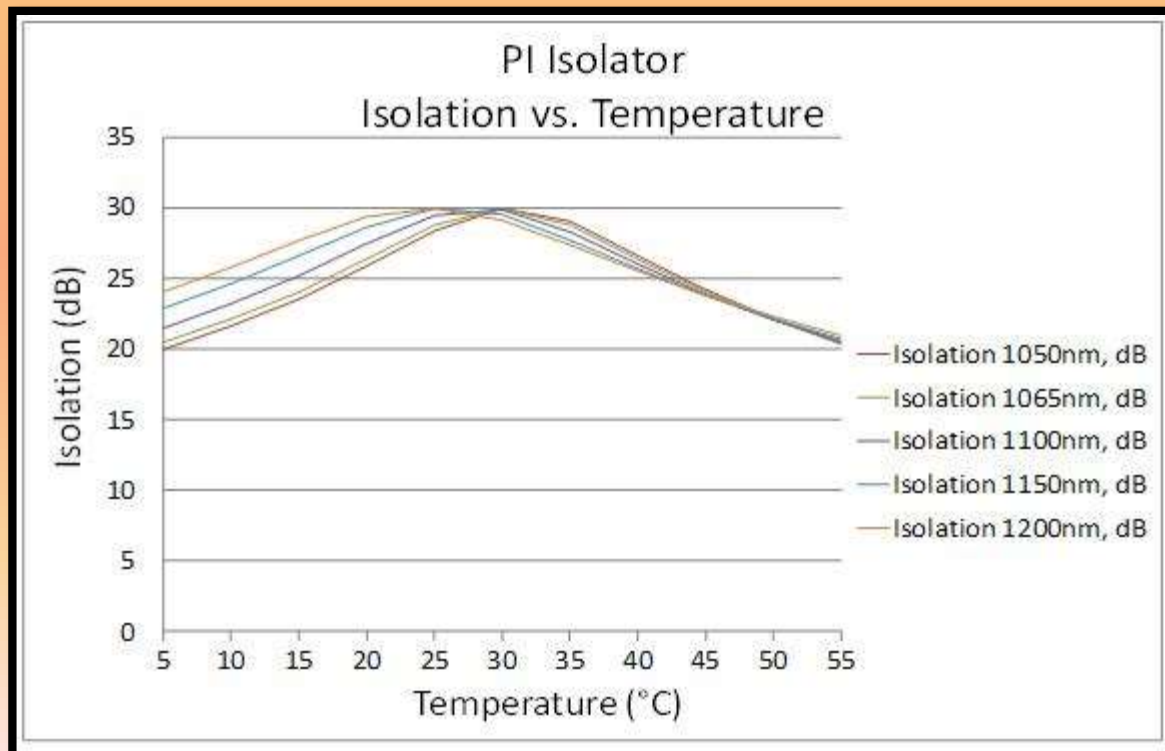

# Laser

- WHAT IS LASER
- TYPES OF LASER
- APPLICATIONS OF LASER
- HOW LASER WORKS

# What is Laser

- ▶ LASER stands for Light Amplification by Stimulated Emission of Radiation. A laser is a device which produces highly directional light. It emits light through a process called stimulated emission of radiation which increases the intensity of light.
- ▶ The laser light spreads in a small region of space. Hence, all the energy is concentrated on a narrow region. Therefore, laser light has greater intensity than the ordinary light.
- ▶ The laser beam is very narrow and can be concentrated on a very small area. This makes laser light highly directional.

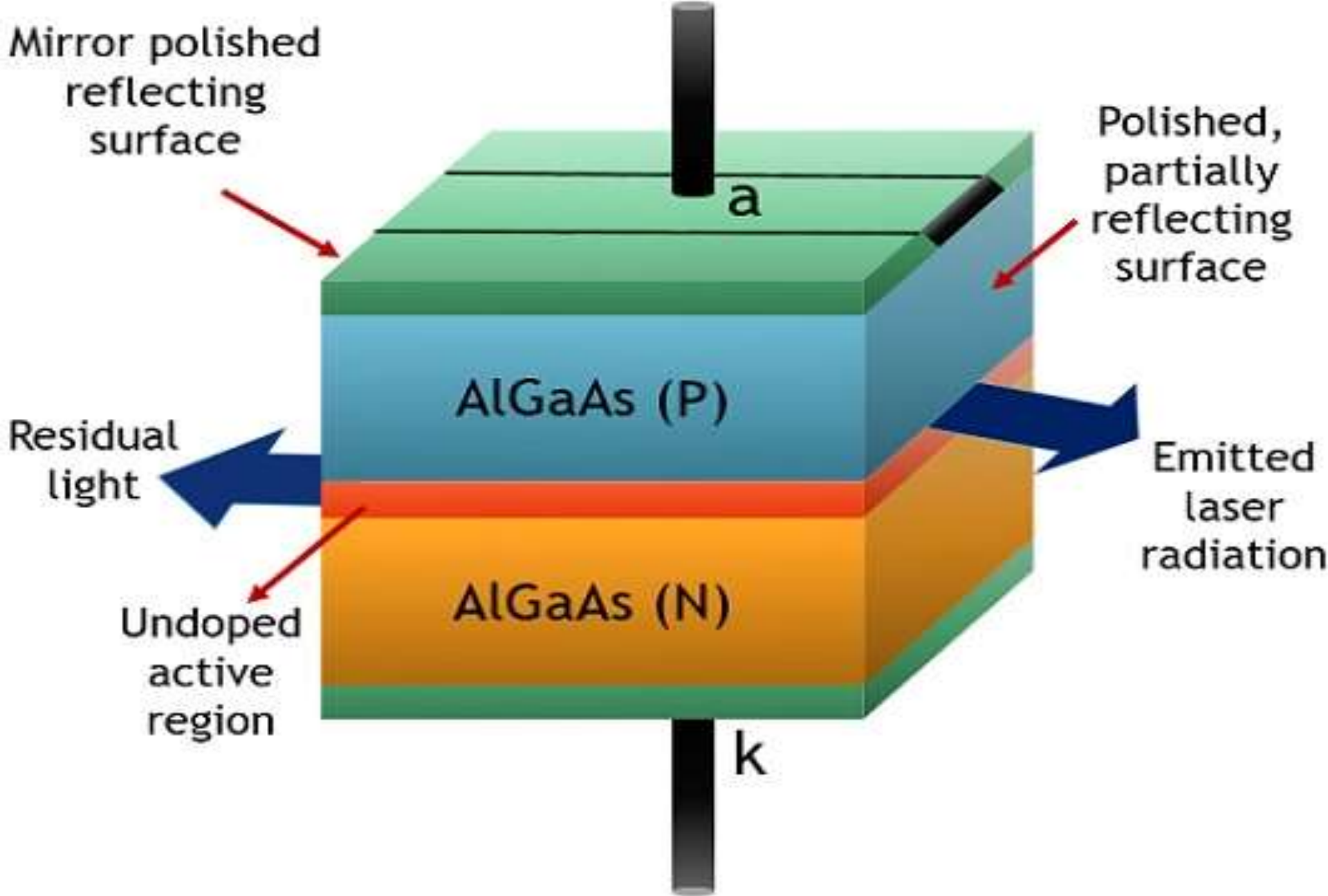

Constructional detail of laser diode

# HOW LASERS WORK

- ▶ **“Laser”** is an acronym for light amplification by stimulated emission of radiation. A laser is created when the electrons in atoms in special glasses, crystals, or gases absorb energy from an electrical current or another laser and become “excited.” The excited electrons move from a lower-energy orbit to a higher-energy orbit around the atom’s nucleus. When they return to their normal or “ground” state, the electrons emit photons (particles of light)

## How a Laser Diode Works?

The working of a laser diode takes place in three main steps:

### Energy Absorption

The laser diode consists of a p-n junction where holes and electrons exist. (Here, a hole means the absence of an electron). When a certain voltage is applied at the p-n junction, the electrons absorb energy and they transition to a higher energy level. Holes are formed at the original position of the excited electron. The electrons stay in this excited state without recombining with holes for a very small duration of time, termed as “recombination time” or “upper-state lifetime”. The recombination time is about a nanosecond for most laser diodes.

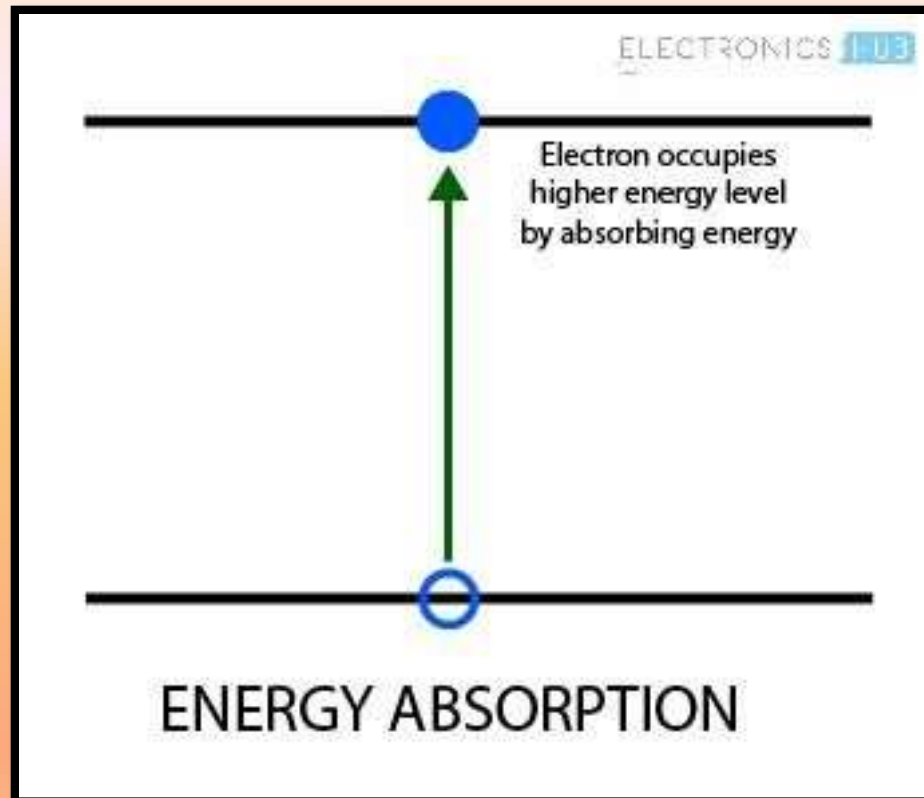

## Spontaneous Emission

After the upper-state lifetime of excited electrons, they recombine with holes. As the electrons fall from higher energy level to a lower energy level, the difference in energy is converted into photons or electromagnetic radiation. This same process is used to produce light in LEDs. The energy of the emitted photon is given by the difference between the two energy levels.

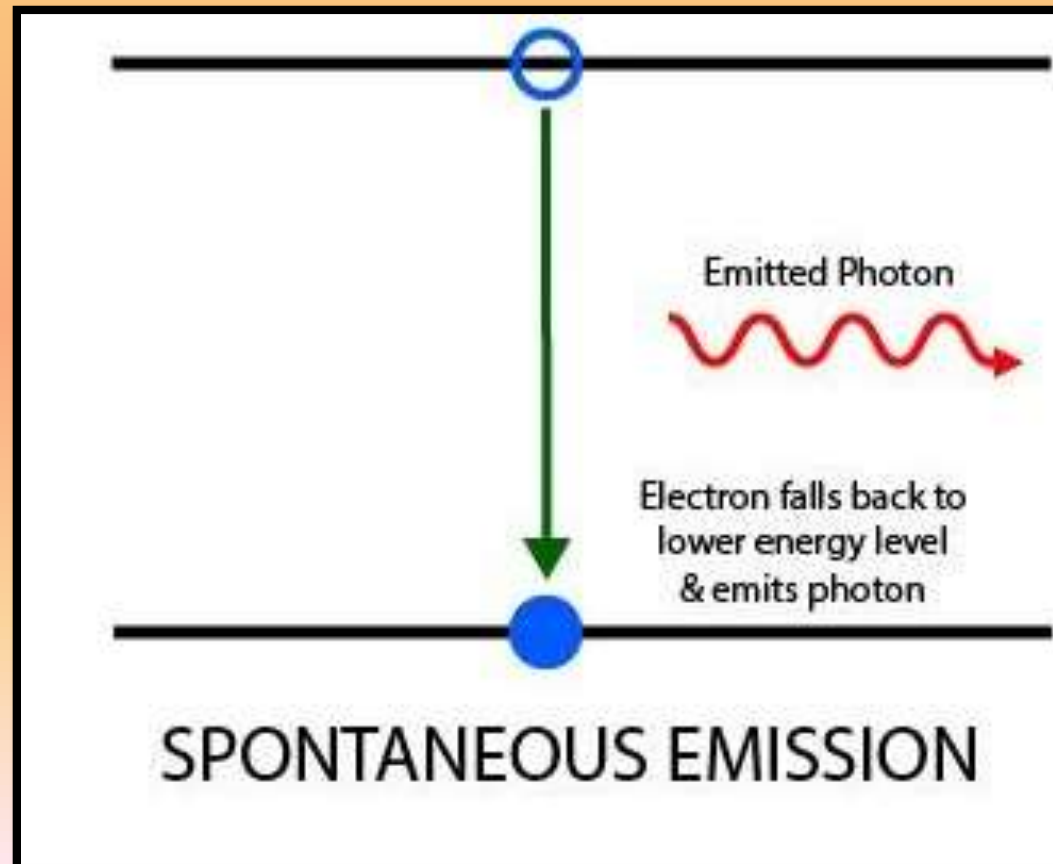

## Stimulated Emission

We need more coherent photons from the laser diode than the ones emitted through the process of spontaneous emission. A partially reflecting mirror is used on either side of the diode so that the photons released from spontaneous emission are trapped in the p-n junction until their concentration reaches a threshold value. These trapped photons stimulate the excited electrons to recombine with holes even before their recombination time. This results in the release of more photons that are in exact phase with the initial photons and so the output gets amplified. Once the photon concentration goes above a threshold, they escape from the partially reflecting mirrors, resulting in a bright monochromatic coherent light.

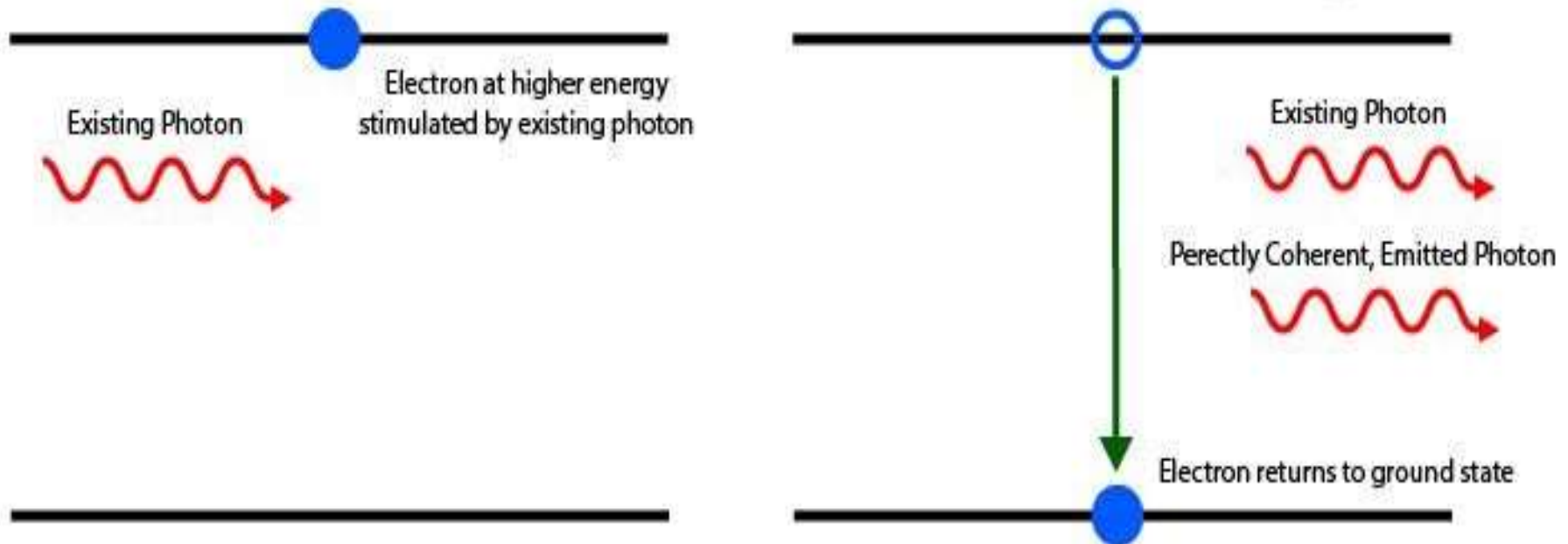

STIMULATED EMISSION

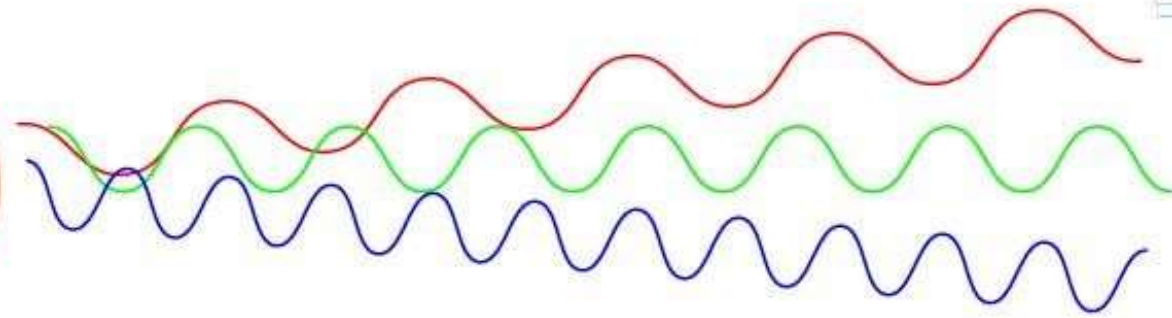

Multiple Frequencies,  
Non-Coherent

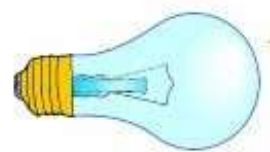

INCANDESCENT  
BULB

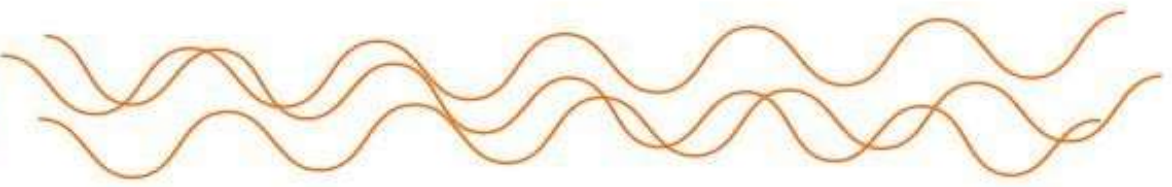

Single Frequency,  
Non Coherent



Single Frequency,  
Coherent

# Construction of a Laser Diode

A simple semiconductor laser diode is made up of the following parts in order:

Metal Contact

P-type Material

Active/Intrinsic Region (N-type Material)

N-type Material

Metal Contact

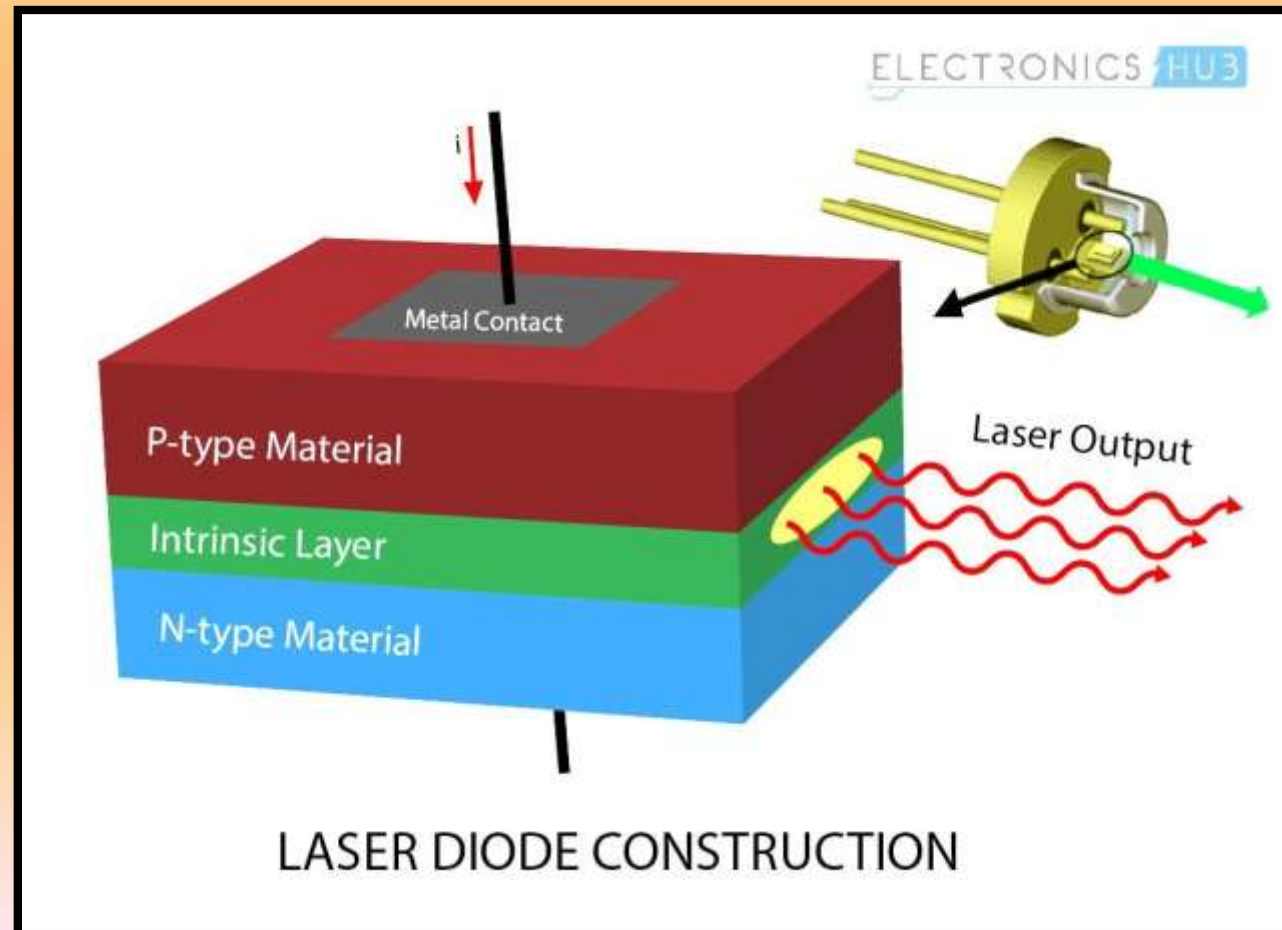

The input terminals are connected to a metal plates which are sandwiched to the n-type and p-type layers. This type of laser diode is also called as a “Homojunction Laser Diode”. The intrinsic region between the p-type and n-type material is used to increase the volume of active region, so that more number of holes and electrons can accumulate at the junction. This allows more number of electrons to recombine with holes at any instant of time, resulting in better output power.

The laser light is emitted from the elliptical region. This beam from the laser diode can be further focused using an optical lens. This entire PIN diode (P-type, Intrinsic, N-Type) arrangement is enclosed normally in a metal casing.

# Types of Laser Diodes

## Double Heterostructure Laser Diode

In this type of laser diodes, an additional confinement layer of a different material is sandwiched between the two p-type and n-type materials. Each of the junction between different materials is called a heterostructure. Because of presence of two heterostructures, this type of laser diode is named as a double heterostructure (DH) laser diode. The advantage of this DH laser diode is that that the active region is confined to a thin layer which gives better optical amplification.

The advantage of the double heterojunction laser diode over other types is that the holes and electrons are confined to the thin middle layer which acts as the active region. By containing the electrons and holes within this area more effectively, more electron-hole pairs are available for the laser optical amplification process. Additionally the change in material at the heterojunction helps contain the light within the active region providing additional benefit.

## Quantum Well Laser Diode

The quantum well laser diode has a very thin middle layer, which acts as a quantum well. The electrons will be able to use quantum energy levels when transitioning from higher energy level to lower energy level. This gives a better efficiency for this type of laser diode.

**Distributed feedback laser diode:** Distributed feedback laser diodes, DFB, are used in forms of telecommunications or data transmission using optical systems. Here the laser diode wavelength is important, but laser diodes are not particularly stable in this respect with wavelength varying with temperature, voltage, ageing, etc.

A diffraction grating is etched close to the p-n junction of the diode to assist in stabilizing the wavelength of the generated light signal, This grating acts like an optical filter causing a single wavelength to be fed back to the gain region. The pitch of the grating is set during manufacture, and this only varies slightly with temperature.

# Quantum Well Laser

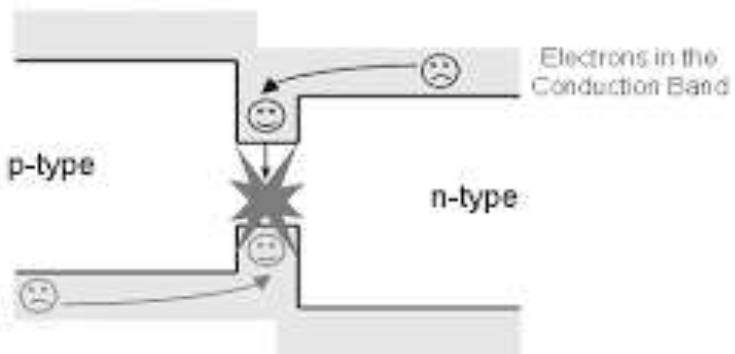

# Double Heterostructure

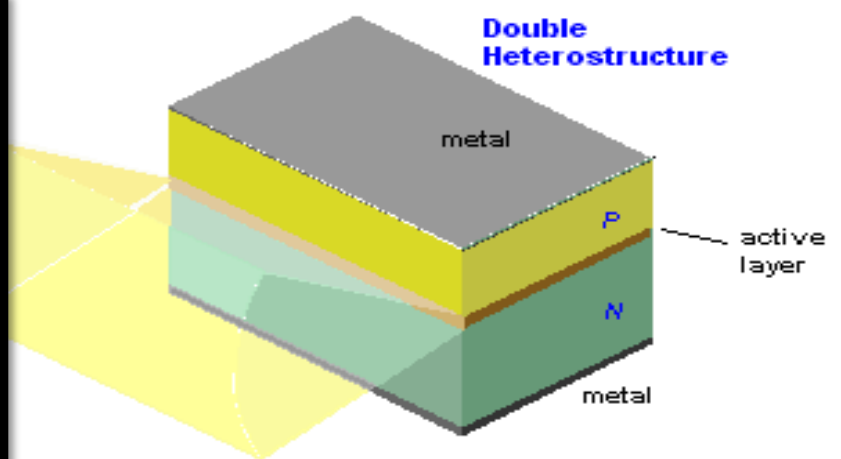

Power (W)

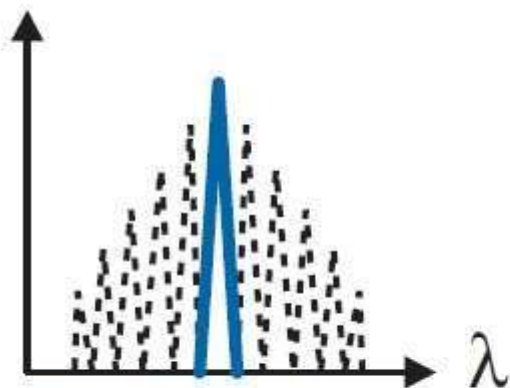

(Emitted Spectrum)

End Mirror

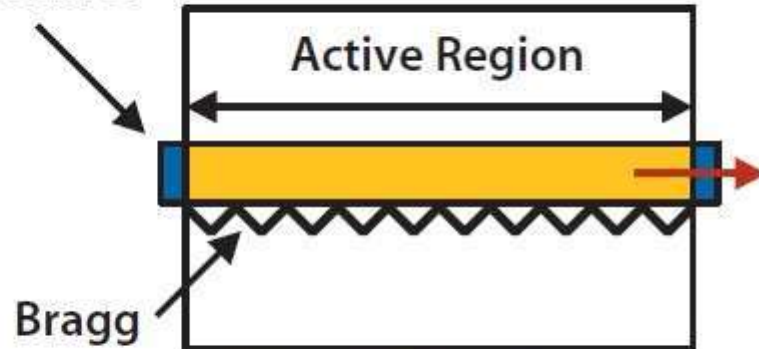

(Schematic Diagram)

Distributed Feedback Laser

# APPLICATIONS OF LASER

- ▶ **Lasers in medicine –**
- ▶ Lasers are used for bloodless surgery.
- ▶ Lasers are used to destroy kidney stones.
- ▶ Lasers are used in cancer diagnosis and therapy.
- ▶ Lasers are used for eye lens curvature corrections
  
- ▶ **Lasers in communications –**
- ▶ Laser light is used in optical fiber communications to send information over large distances with low loss.
- ▶ Laser light is used in underwater communication networks.
- ▶ Lasers are used in space communication, radars and satellites.

## ▶ Lasers in Industries-

- ▶ Lasers are used to cut glass and quartz.
- ▶ Lasers are used in electronic industries for trimming the components of Integrated Circuits (ICs).
- ▶ Lasers are used for heat treatment in the automotive industry.

- ▶ Lasers in Military-
- ▶ Laser range finders are used to determine the distance to an object.
  
- ▶ Lasers in Science and Technology-
- ▶ A laser helps in studying the Brownian motion of particles.
- ▶ Lasers are used to store large amount of information or data in CD-ROM.
- ▶ Lasers are used to measure the pollutant gases and other contaminants of the atmosphere.
- ▶ Lasers helps in determining the rate of rotation of the earth accurately.
- ▶ Lasers are used in computer printers.
- ▶ Lasers are used for producing three-dimensional pictures in space without the use of lens.

# UNIT 5

# OPTICAL DETECTORS

An optical detector is a device that converts light signals into electrical signals, which can then be amplified and processed. The photodetector is as essential an element of any fiber optic system as the optical fiber or the light source. Photodetectors can dictate the performance of a fiber optic communication link.

## **Semiconductor Photodiodes**

Semiconductor photodiodes are the most commonly used detectors in optical fiber systems since they provide good performance, being small in size, and are of low cost.

Semiconductor photodiodes are made of silicon, germanium, GaAs, InGaAs, etc.

## **How Does a Photodetector Work?**

The following illustration shows how a photodetector work. The detector is electrically reverse-biased

No light

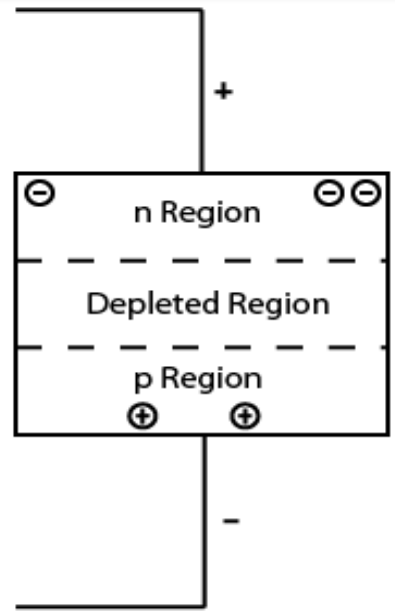

Diode is reverse-biased, no current flows.

Light forms  
electron-hole  
pairs

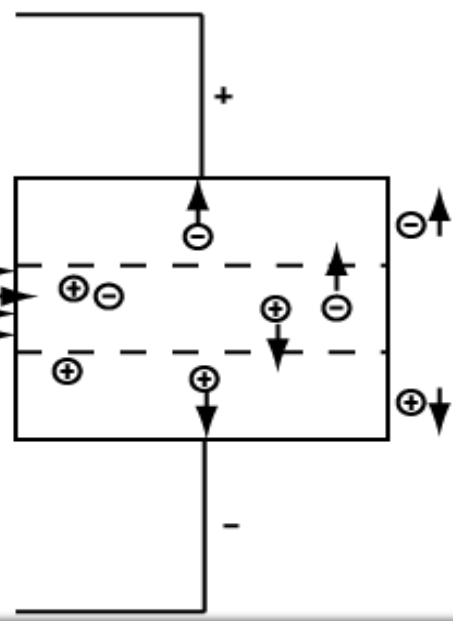

Current flows

In the first illustration when there is no light, the reverse bias draws current-carrying electrons and holes out of the p-n junction region, creating a depleted region, which stops current from passing through the diode.

In the second illustration when there are lights on the detector, photons with the proper energy (wavelength) can create electron-hole pairs in this region by raising an electron from the valence band to the conduction band, leaving a hole behind. The bias voltage causes these current carriers to drift quickly away from the junction region, so a current flows proportional to the light hitting the detector.

# Characteristics of Photo Detectors

- ✓ High sensitivity at the operating wavelength of the source
- ✓ Excellent Charge transport (high mobility)
- ✓ Low leakage current (Dark current)
- ✓ Efficient production of electron-hole pairs due to radiation
- ✓ Sufficient area for efficient coupling to optical fiber
- ✓ Low Noise for reduced errors
- ✓ Linear response over a wide range of light intensity
- ✓ Fast Response to operate at high frequencies
- ✓ Stability of performance characteristics
- ✓ Low bias voltage
- ✓ High Reliability
- ✓ Low cost

# PIN DIODE

- The symbol of PIN photodiode is similar to the normal p-n junction diode except that it contains arrows striking the diode. The arrows striking the diode represent light or photons.

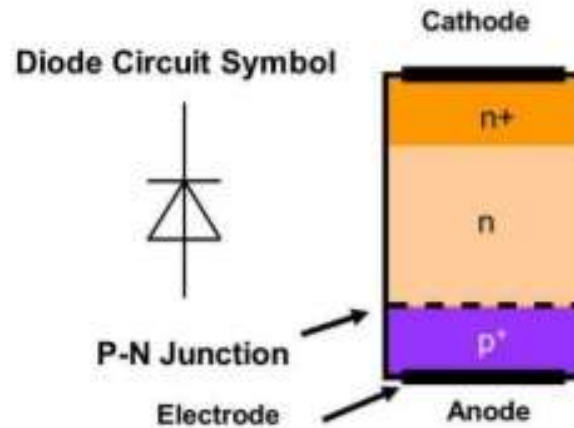
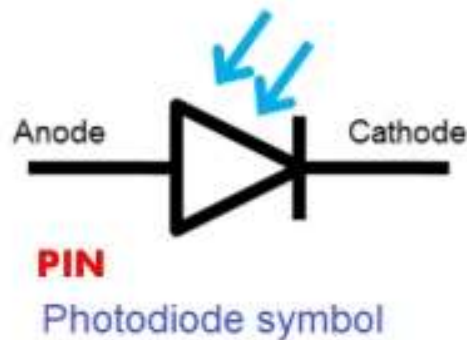

## INTRODUCTION

- A **PIN diode** is a diode with a wide, lightly doped 'near' intrinsic semiconductor region between a p-type semiconductor and an n-type semiconductor region. The p-type and n-type regions are typically heavily doped because they are used for ohmic contacts.
- The wide intrinsic region is in contrast to an ordinary PN diode. The wide intrinsic region makes the PIN diode an inferior rectifier (one typical function of a diode), but it makes the PIN diode suitable for attenuators, fast switches, photodetectors, and high voltage power electronics applications.

PIN photodiode has an intrinsic (very lightly doped) semiconductor region sandwiched between a p-doped and an n-doped region. The PIN photodiode is reverse-biased as shown above. Since the intrinsic (i) region has no free charges, its resistance is high, so that most of the reverse-biased voltage is applied to this i region.

The i region is usually wide so that incoming photons have a greater probability of absorption in the i region rather than in the p or n regions.

Since the electric field is high in the i region, any electron-hole pairs generated in this region are immediately swept away by the field. e-h pairs generated in the p and n regions have to first diffuse into the depletion

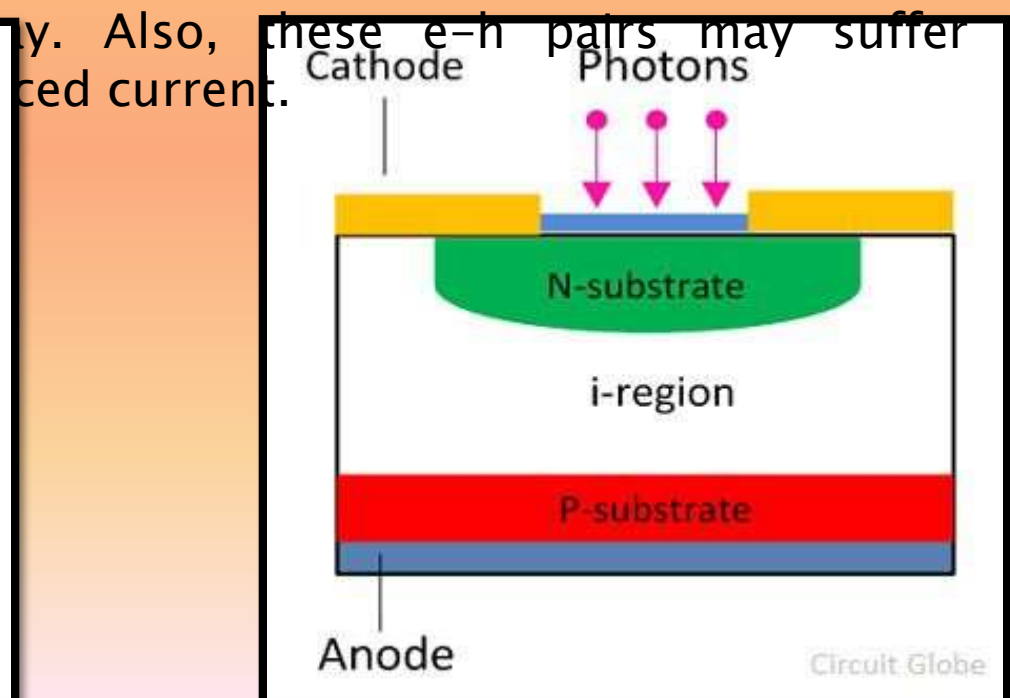
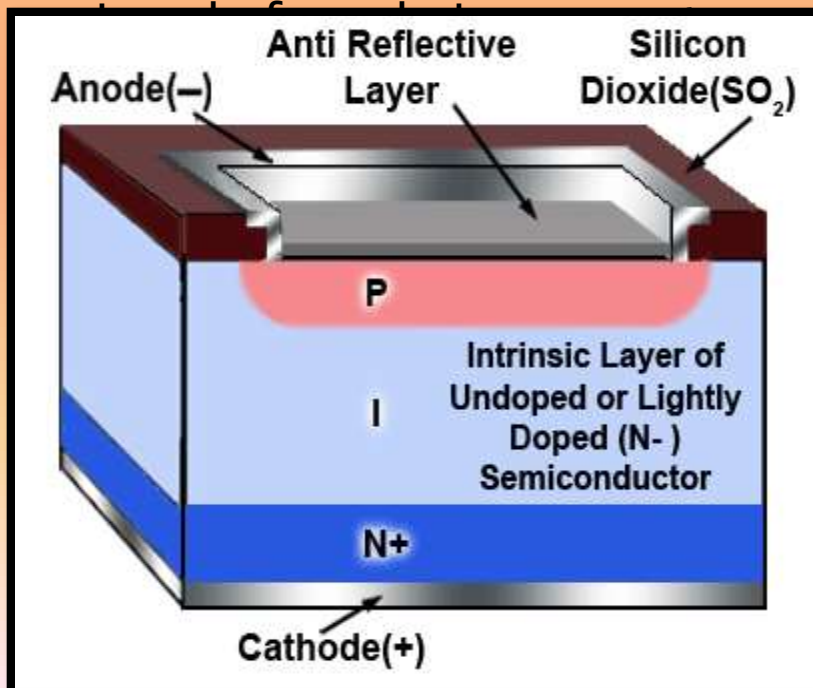

## 1.5: Applications of PIN diodes:-

---

PIN diodes is used primarily in UHF and microwave applications . They are also used as rf switches in many amateur radio systems. The low reverse capacitance and current -controlled resistance make it ideal for high-frequency communication circuits.

The most common applications of PIN diodes are:-

- ▶ Switches
- ▶ Limiters
- ▶ Modulators
- ▶ Photo-detector

Avalanche photodiodes are used in applications where very sensitive light detection is needed.

Avalanche photodiodes can be used in a number of applications to provide performance that other types of photodiode may not be able to attain.

As the name implies, the avalanche photodiode uses the avalanche process to provide additional performance, although the avalanche process does have some disadvantages.

In view of the advantage and disadvantages, avalanche photodiodes are used in a number of niche applications where their characteristics enable them to provide the additional sensitivity that may be required.

# Avalanche Photodiodes

- High gain due to avalanche multiplication effect
- Increased noise
- Silicon has high gain but low noise
- Si-InGaAs APD often used (diagram on right)

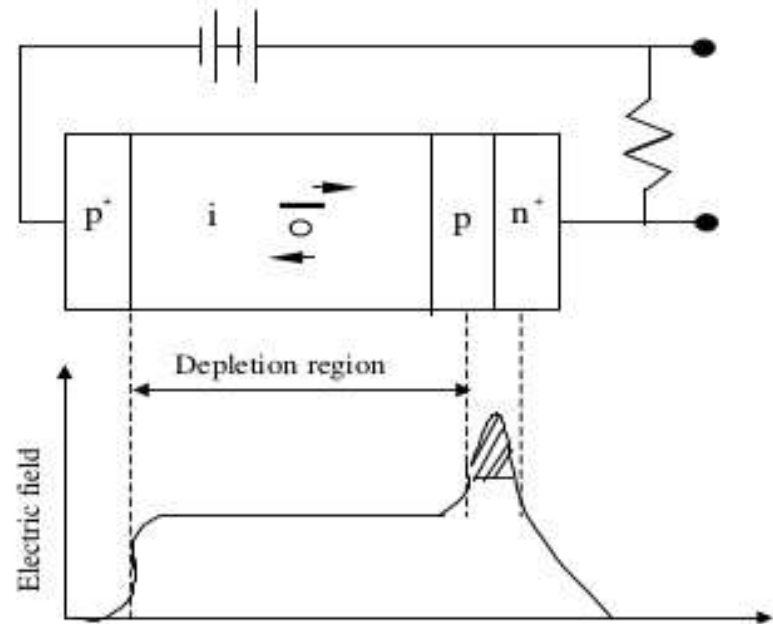

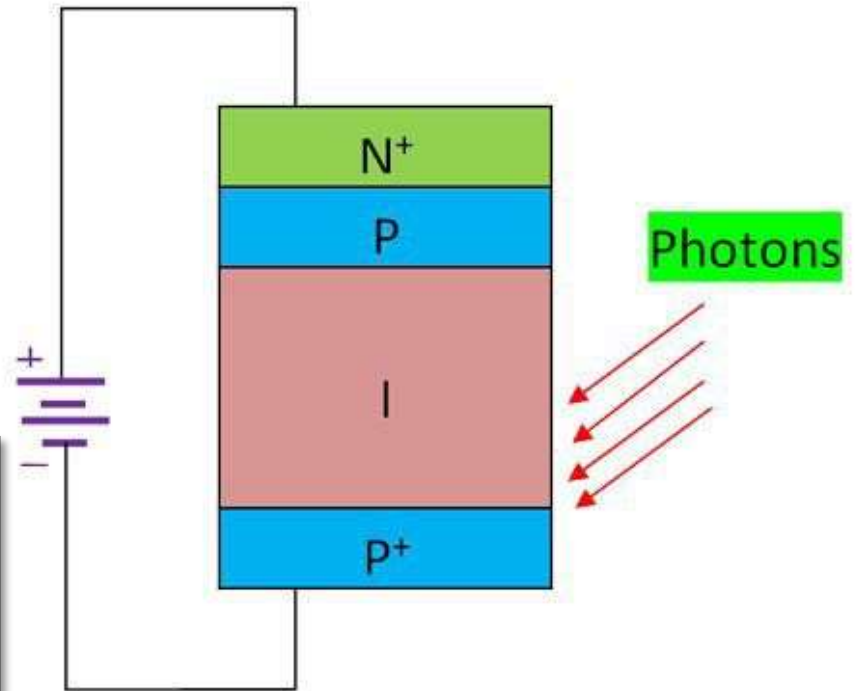

**Avalanche Photodiode**

Electronics Coach

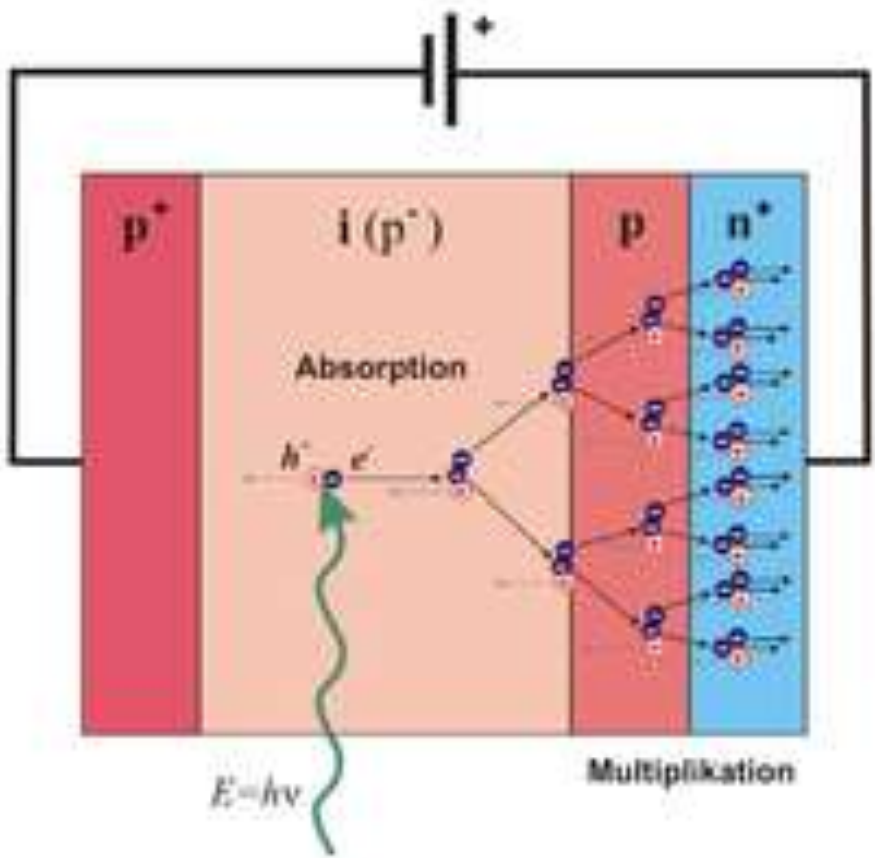

*THE AVALANCHE PHOTODIODE* possesses a similar structure to that of the PN or PIN photodiode.

The main difference of the avalanche photodiode to other forms of photodiode is that it operates under a high reverse bias condition. This enables avalanche multiplication of the holes and electrons created by the photon / light impact.

As a photon enters the depletion region and creates a hole electron pair, these charge carriers will be pulled by the very high electric field away from one another. Their velocity will increase to such an extent that when they collide with the lattice, they will create further hole electron pairs and the process will repeat.

The avalanche action enables the gain of the diode to be increased many times, providing a very much greater level of sensitivity.

## **Avalanche photodiode disadvantages:**

- Avalanche photodiodes allow precise and fast measurements especially when only low signal levels are available in optical communication or distance measurement.
- Much higher operating voltage may be required.
- Avalanche photodiode produces a much higher level of noise than a PN photodiode
- Avalanche process means that the output is not linear

## **The typical applications of APDs thus include:**

- encoders, laser scanners / LIDAR systems, laser alignment systems
- analytical instruments, spectrometers
- laser rangefinders and trackers, distances and speed

### Comparison:

Sr. no.	PIN diode	APD (Avalanche photodiode)
1	PIN does not have high intensity electric field region.	APD has high intensity electric field region.
2	Photo current ( $I_p$ ) generated is less compared to APD $I_p = qN_e$ $q = \text{electron charge}$ $N_e = \text{carrier number}$	Photo current ( $I_p$ ) generated is more compared to PIN $I_p = qN_e \cdot M$ $q = \text{electron charge}$ $N_e = \text{carrier number}$ $M = \text{multiplication factor}$
3	<u>Responsivity</u> of PIN is limited.	<u>Responsivity</u> of APD can have much larger values.
4	They exhibit lower noise levels.	They exhibit higher noise levels as compared to PIN due to impact ionization and photocurrent multiplication.
5	Response time of PIN is half that of APD.	Response time of APD is almost double that of PIN.



## APD vs PIN

---

- In general, APDs are only useful for digital systems because they possess very poor linearity.
- Because of the added circuit complexity and the high voltages that the parts are subjected to, APDs are always less reliable than PIN detectors.
- At lower data rates, PIN detector-based receivers can almost match the performance of APD-based receivers, makes PIN detectors the first choice for most deployed low-speed systems.
- At multigigabit data rates, however, APDs rule supreme.

# APPLICATIONS

- PIN photodiode → most widely used
  - Audio CD players
  - DVD players
  - Computer CD drives
  - Optical communication systems
  - Nuclear radiation detectors
- APD → level of gain is of importance for high voltage requirement.
  - Laser range finders
  - fast receiver modules for data communications
  - high speed laser scanner (2D bar code reader)
  - speed gun
  - PET Scanner
  - microscopy and particle detection.

# MERITS

- PIN → detect high energy charged or uncharged particles & also electromagnetic radiation
  - no gain, so useful in some applications
  - no high operating voltage required
  - low noise & cost
  - high efficiency
  - long lifetime
- APD → large gain
  - greater level of sensitivity
  - high speed

# Sources of noise in an optical receiver

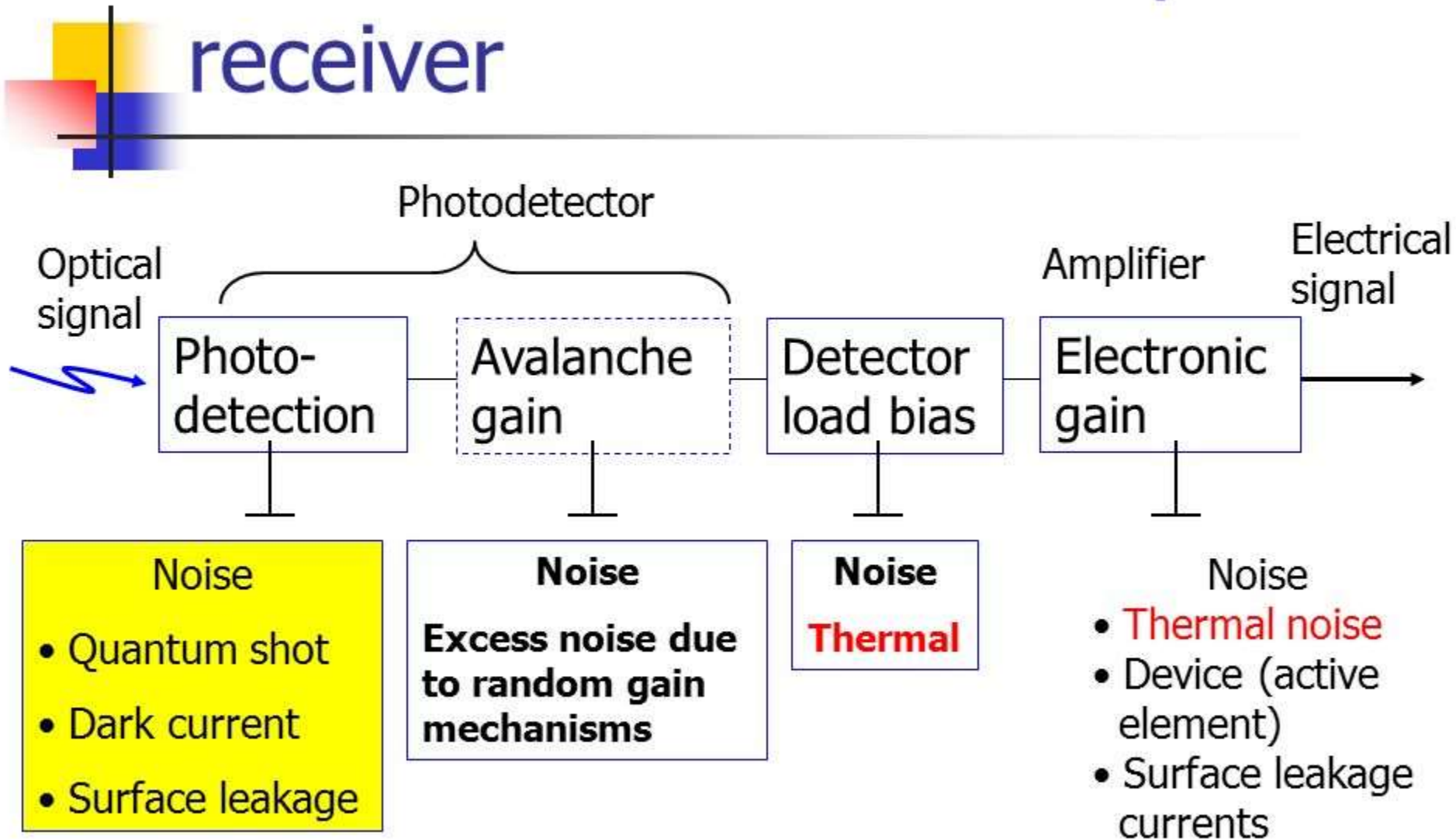

# Noise Sources in a Receiver

The term *noise* describes unwanted components of an electric signal that tend to disturb the transmission and processing of the signal

- The random arrival rate of signal photons produces quantum (shot) noise
- Dark current comes from thermally generated  $eh$  pairs in the  $pn$  junction
- Additional shot noise arises from the statistical nature of the APD process
- Thermal noises arise from the random motion of electrons in the detector load resistor and in the amplifier electronics

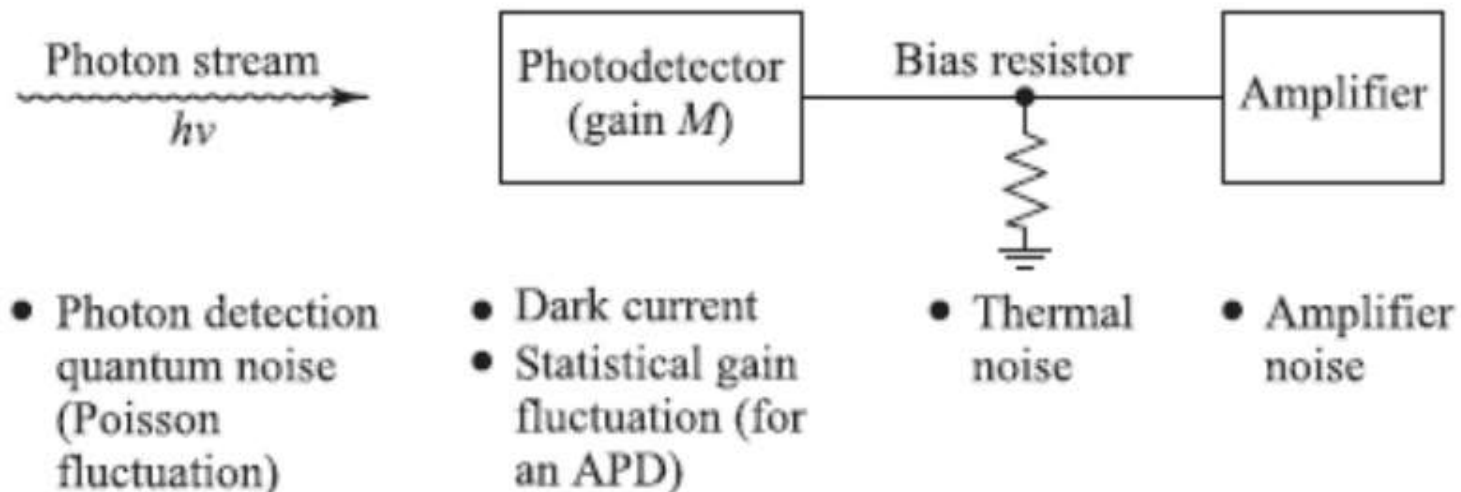

# Photodetector Noise

- In fiber optic communication systems, the photodiode is generally required to **detect very weak optical signals**.
- Detection of weak optical signals requires that the photodetector and its amplification circuitry be optimized to **maintain a given signal-to-noise ratio**.
- The **power signal-to-noise ratio S/N** (also designated by SNR) at the output of an optical receiver is defined by

$$SNR = \frac{S}{N} = \frac{\text{signal power from photocurrent}}{\text{photodetector noise power} + \text{amplifier noise power}}$$

**SNR Can NOT be improved by amplification**

## Noise sources in optical detectors

Noise is a term generally used to refer to any undesired disturbances that mask the received signal in communication system.

The maximum information you can extract from an image is limited by its signal-to-noise ratio ( $SNR$ ). With signal defined as the amount of light incident upon the detector per unit time, noise can be seen as the “disturbance” on the signal level that hinders an accurate measurement.

Optical detectors are subjected to

Optical shot noise ( $N_s$ ): inherent noise in counting a finite number of photons per unit time. The number of photons emitted by all optical sources including coherent source in a given time is never constant. Deviation of actual number of photons from average number.

Dark current noise ( $N_d$ ): thermally induced “firing” of the detector. When there is no optical power incident on photo detector a small leakage current still flows from the device terminals and this contributes to total system noise

## *Necessity of Optical Amplifiers:*

- ❖ Optical Amplifiers boost up the power level of multiple light wave signals
- ❖ To Transmit signals over long distances(>100km)
- ❖ To compensate attenuation losses.

# Basic Concepts

- Most optical amplifiers use stimulated emission
- An optical amplifier is basically a laser without feedback
- Optical gain is realized when the amplifier is pumped optically (or electrically) to achieve *population inversion*
- Gain depends on wavelength, internal light intensity and amplifier medium
- Three types: **semiconductor** optical amplifiers, **Raman** Amplifiers and **fiber doped** amplifiers

## Types of Optical Amplifier

Optical amplifier can be divided into three types now. They are the *doped fiber amplifier, the semiconductor optical amplifier and the Raman amplifier.*

Doped fiber amplifier has several types according to the kinds of rare earth elements. Erbium-doped fiber amplifier is the most common one. its amplifying medium is the fiber doped with erbium elements. The amplified light's wavelength is around 1550 nm, which suffers minimum attenuation. And this amplifier has low noise and is applied in the long-haul telecommunication networks.

The second is semiconductor optical amplifier whose gain medium is undoped InGaAsP. Compared with EDFA, it is less expensive and more suitable for local networks. Raman amplifier's gain medium is undoped optical fiber. It is made with Raman scattering effect which is an important non-linear effect. And this amplifier has been commercialized these days, with sold at a high price.

The advent of optical amplifier is a great success in optical fiber communication technology. At present, it has been become a basic device in modern telecommunication networks and brings much effectiveness to economy and society, which presents a good trend for the market prospect.

## Working Principles of Optical Amplifier-EDFA

Optical amplifier is a device that can amplifier optical signals directly, which does not need to convert optical signals to electric signals first. And we will take the common kind for example to explain its working principles, namely, **EDFA (erbium doped fiber amplifier)**. Optical fiber is often doped with rare-earth elements, such as erbium or praseodymium which can be pumped into a excited state by pump laser. When input signals pass by the fiber, they will stimulate the excited atoms of erbium so that the atoms of erbium can release their energy in the form of emitted light photons. It is the emitted light photons who has the same phase and wavelength with input signals that amplify the optical signals.

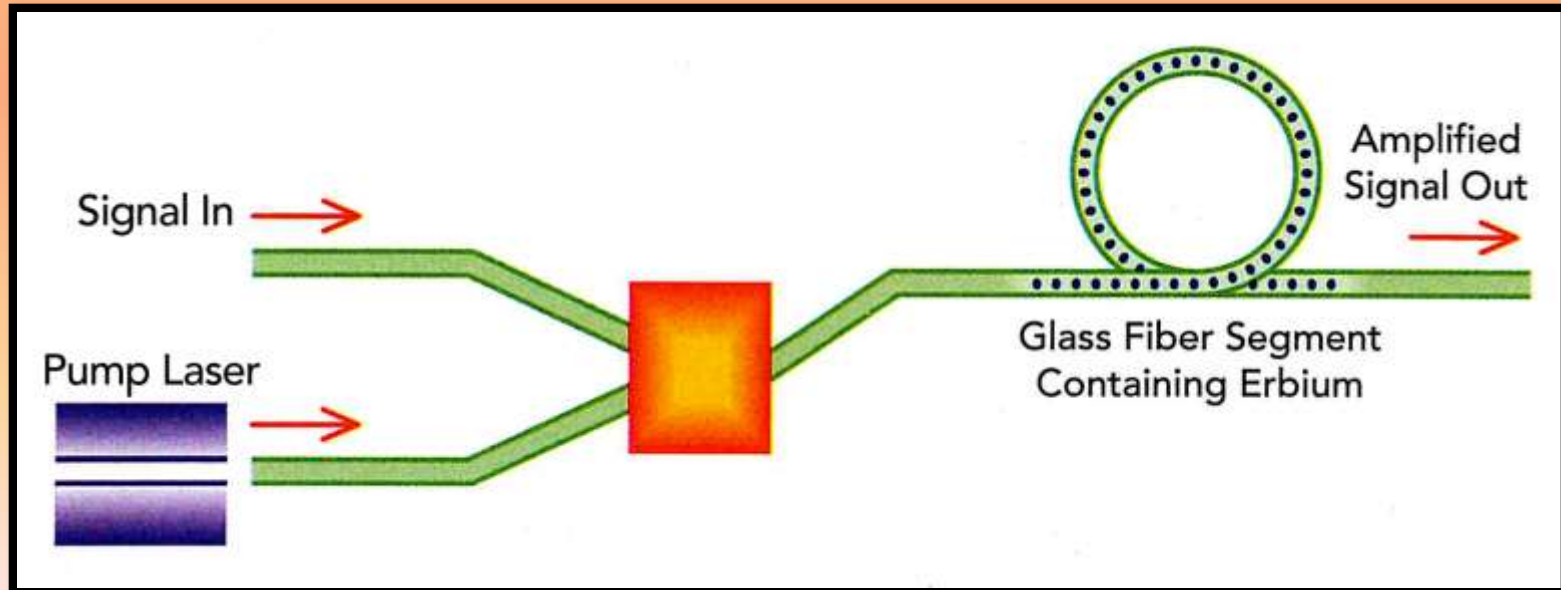

*EDFA includes the ability* :-

- ✓ To pump the devices at several different wavelengths.
- ✓ Low coupling loss to the compatible sized fiber transmission medium.
- ✓ Immune from interference effects (crosstalk and intermodulation distortion) when wavelength channels are injected simultaneously into amplifier

# Semiconductor Amplifier.

- An electrical current passed through the device that excites the electrons in the active region.
  - When photon(light) travel through the active region it can cause these electron to lose some of their extra energy in the form of more photons that match the wavelength of the initial ones.
  - Therefore, an optical signal passing through the active region is amplified and is said to have experienced “gain”.
- 

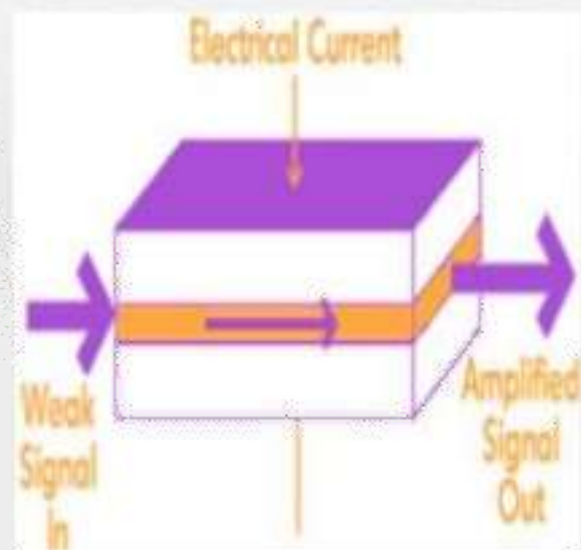

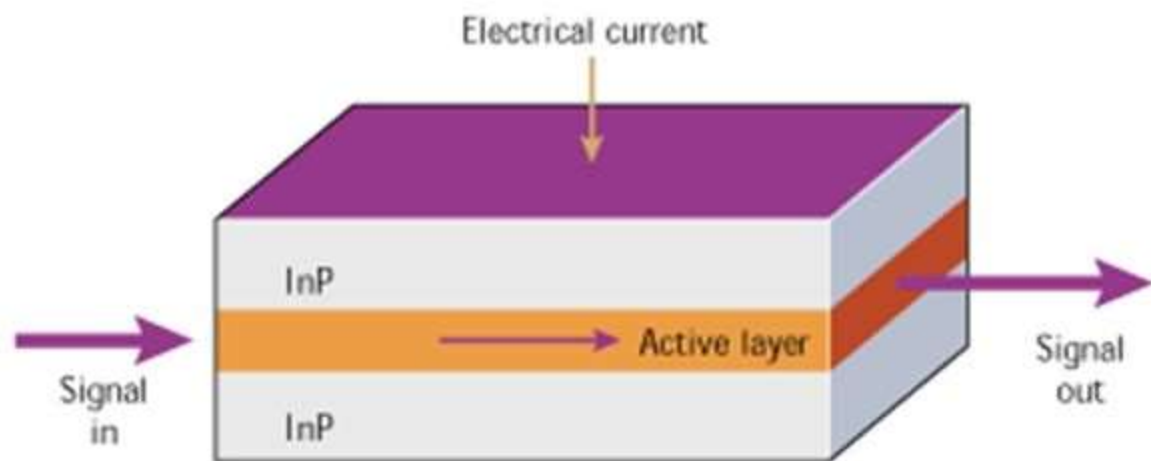

*Semiconductor optical amplifiers, like their semiconductor-laser, consist of gain and passive regions. Layers of antireflective coatings prevent light from reflecting back into the circuit while the incoming signal stimulates electrons in the gain region*

# SOA: Amplification Process.

- Semiconductor have valance and conduction band.
- At thermal equilibrium valance band has higher population.
- Under population inversion condition conduction band will have higher population.
- Population inversion is achieved by forward biasing the p-n junction.

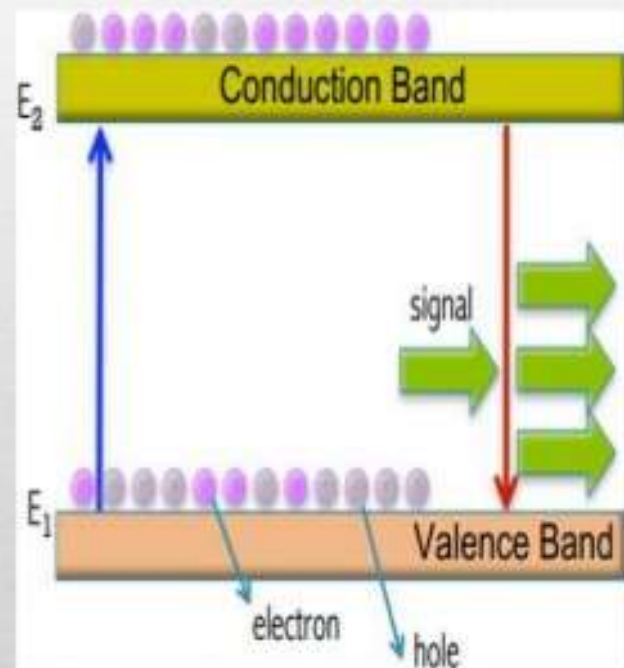

After reaching its excited state, the electron must release some energy and drop to lower level.

Here a signal photon can then trigger the excited electron into stimulated emission and electron releases its remaining energy in the form of new photon.

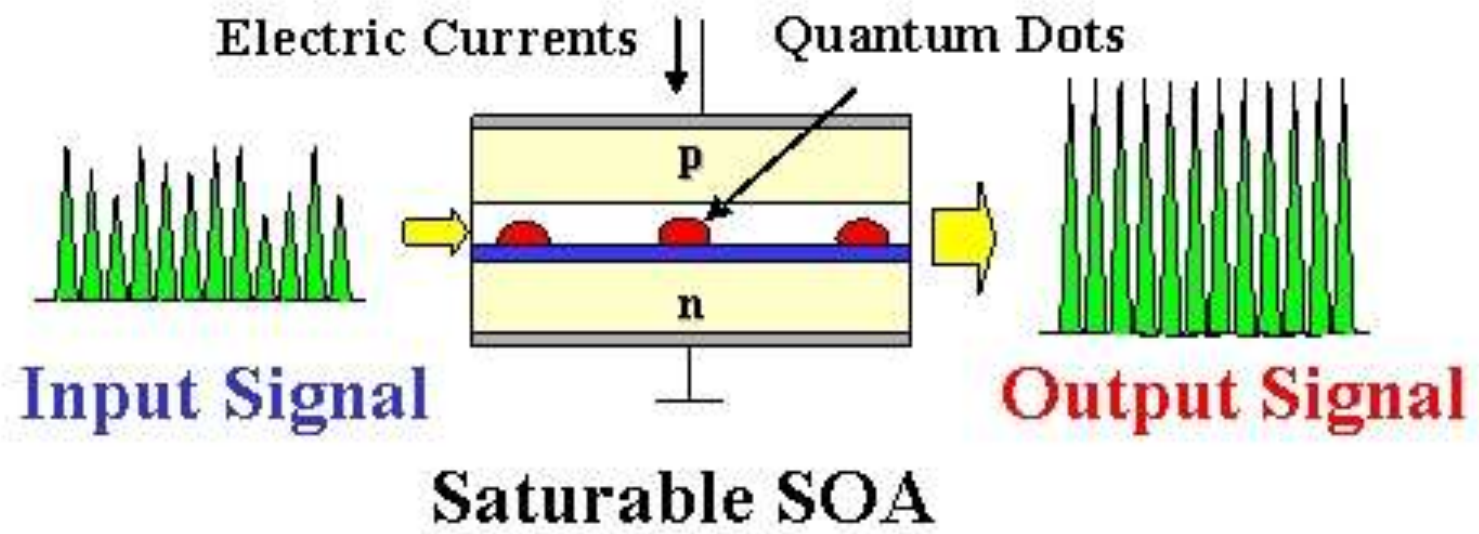

# Semiconductor Optical Amplifier.

## Advantages:

- Small size.
- Transmission bidirectional.
- Smaller output power than EDFA.
- Less expensive than EDFA.

## Limitations:

- Lower gain (20–30 dB) than EDFA.
  - Higher noise (7–12 dB) than EDFA.
  - Polarization dependence.
  - High nonlinearity.
-

**A Raman amplifier** is an optical **amplifier** based on **Raman gain**, which results from the effect of stimulated **Raman scattering**. The **Raman amplifier** makes use of stimulated Raman scattering (SRS) within the fiber, which transfers the energy of higher-frequency pump signals to lower-frequency signals. The **amplification** occurs along the transmission fiber for the distributed Raman amplifier.

Raman amplifiers can be operated in very different wavelength regions, provided that a suitable pump source is available.

A Raman amplifier requires high pump power (possibly raising **laser safety** issues) and high pump **brightness**, but it can also generate high output powers.

Raman fiber amplifiers can have a lower **noise figure**. On the other hand, they more directly couple pump noise to the signal than laser amplifiers do.

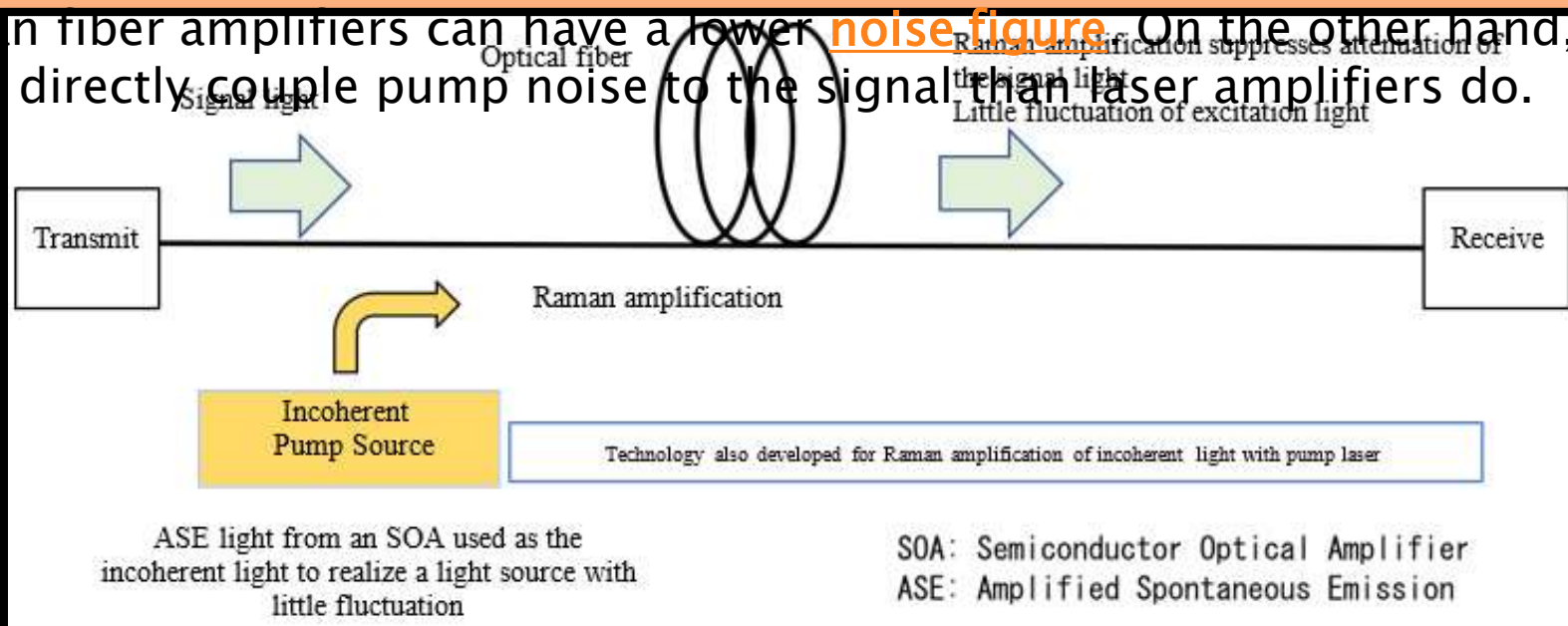

Raman amplification is based upon stimulated Raman scattering in which the photon induces inelastic scattering of the pump photon in the non-linear regime of the medium. This scattering generates another photon with lower frequency (and energy) while the energetic difference (and therefore the frequency difference) is passed to the vibration states of the medium. The main application of this effect is in the field of ultra-fast optics and in optical communications in the generation of all-band wavelength conversion and all-optical direct signal amplification. Figure schematically presents the description of this effect.

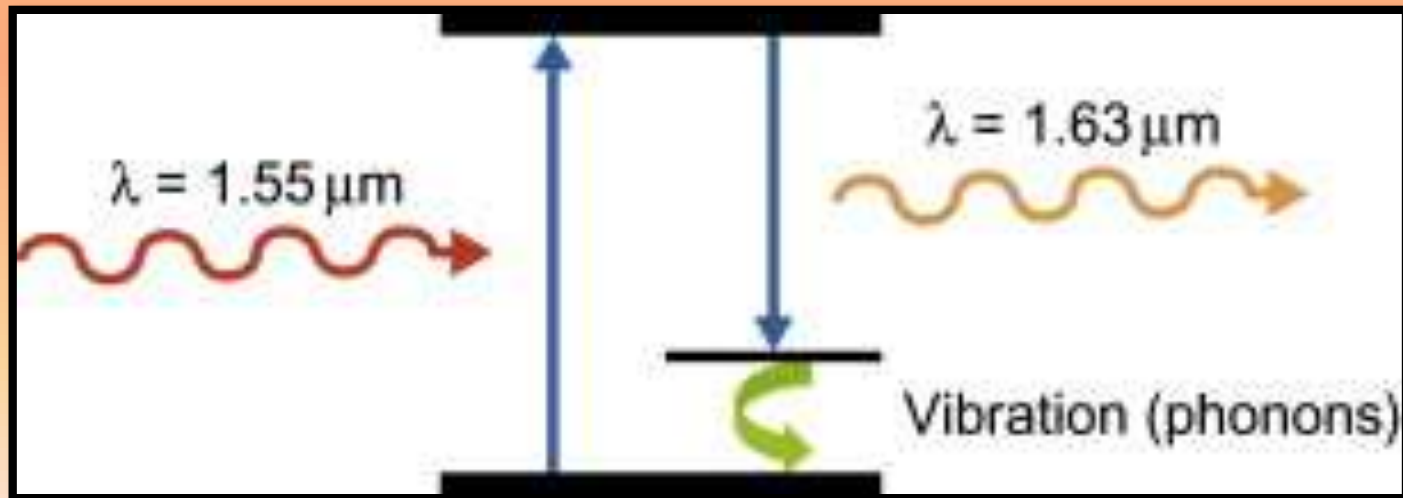

# Raman Amplifier :: Operation

- The physics behind is called Stimulated Raman Scattering
- High energy pump wave is co-launched into the fiber
- Raman gain depends on the pump power and frequency offset between pump and signal
- Pump photon gives up energy to create a signal photon
- Residual vibrational energy is absorbed as phonons

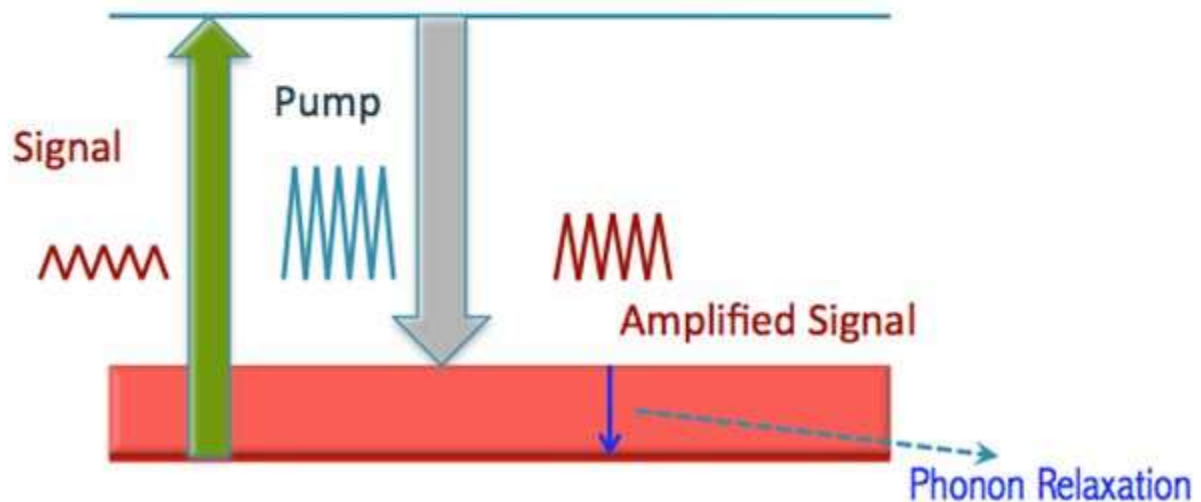

# Raman Amplifier

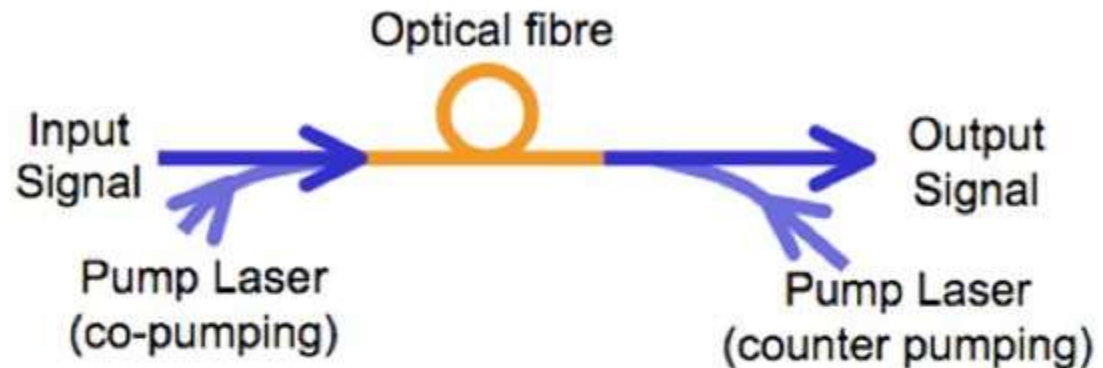

- Topologically simpler to design – no special doping is required
- Uses intrinsic optical nonlinearity of fiber
- Amplification takes place throughout the length of transmission fiber
- Raman pumping is usually done backwards
- Gain is higher at the receiver end of the fiber than at the transmitter end
- This is very useful in compensating for the losses

# Raman Amplifier (RA)

## Advantages:

- Low noise (3–5 dB).
- Wide gain bandwidth (up to 10 nm).
- Distributed amplification within the transmission fiber.

## Limitations:

- Low gain (10 dB).
  - Requirement of high pump power.
-